

U型擁壁配筋図 S=1:50

(その1)

断面図 1-1

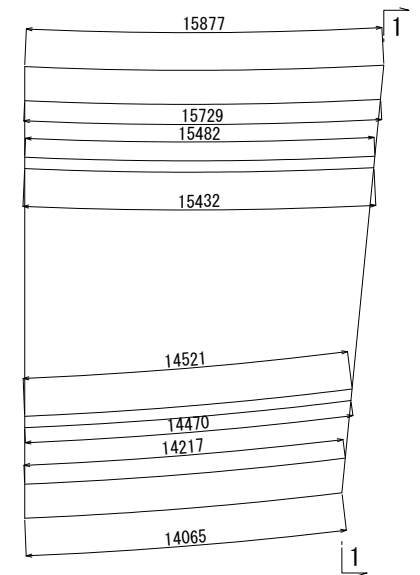
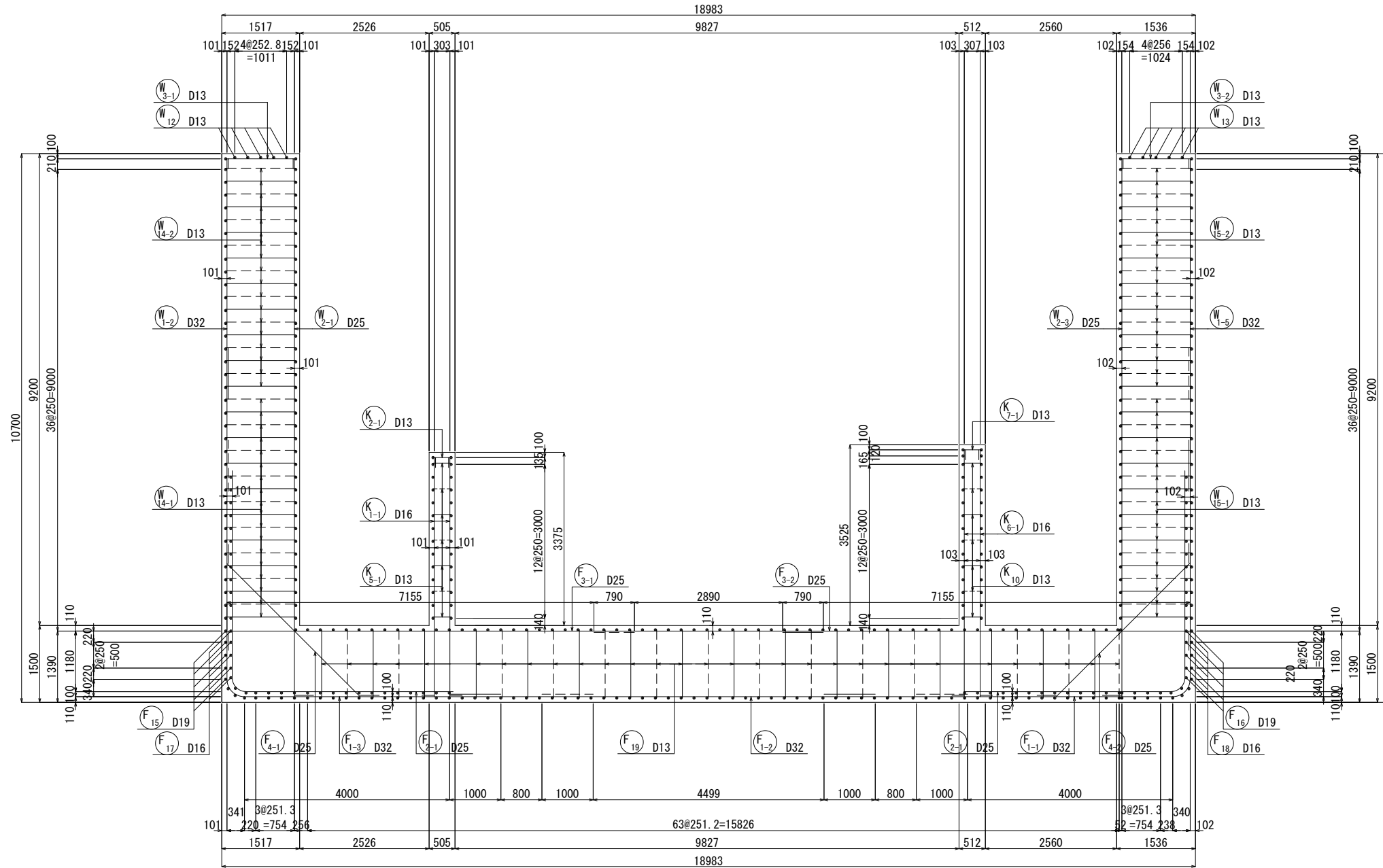

(ctc125)

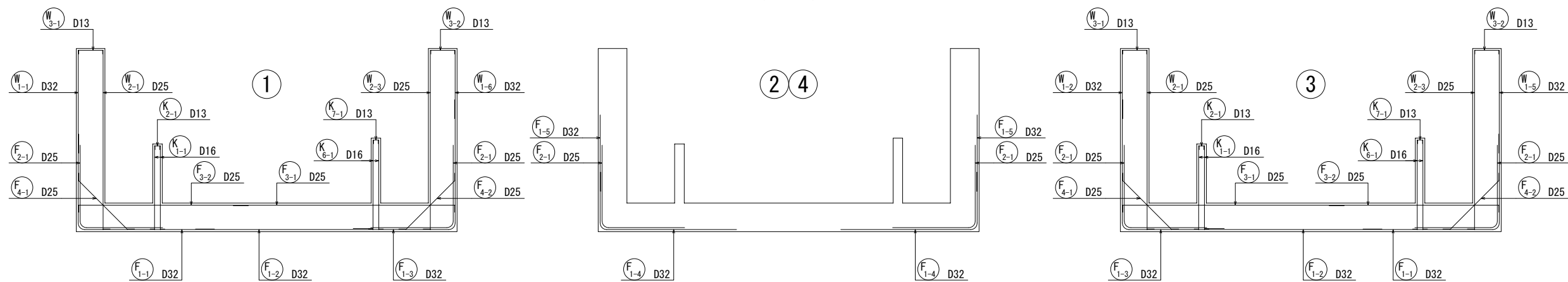

U型擁壁配筋図 S=1:50

(その2)

断面図 2-2

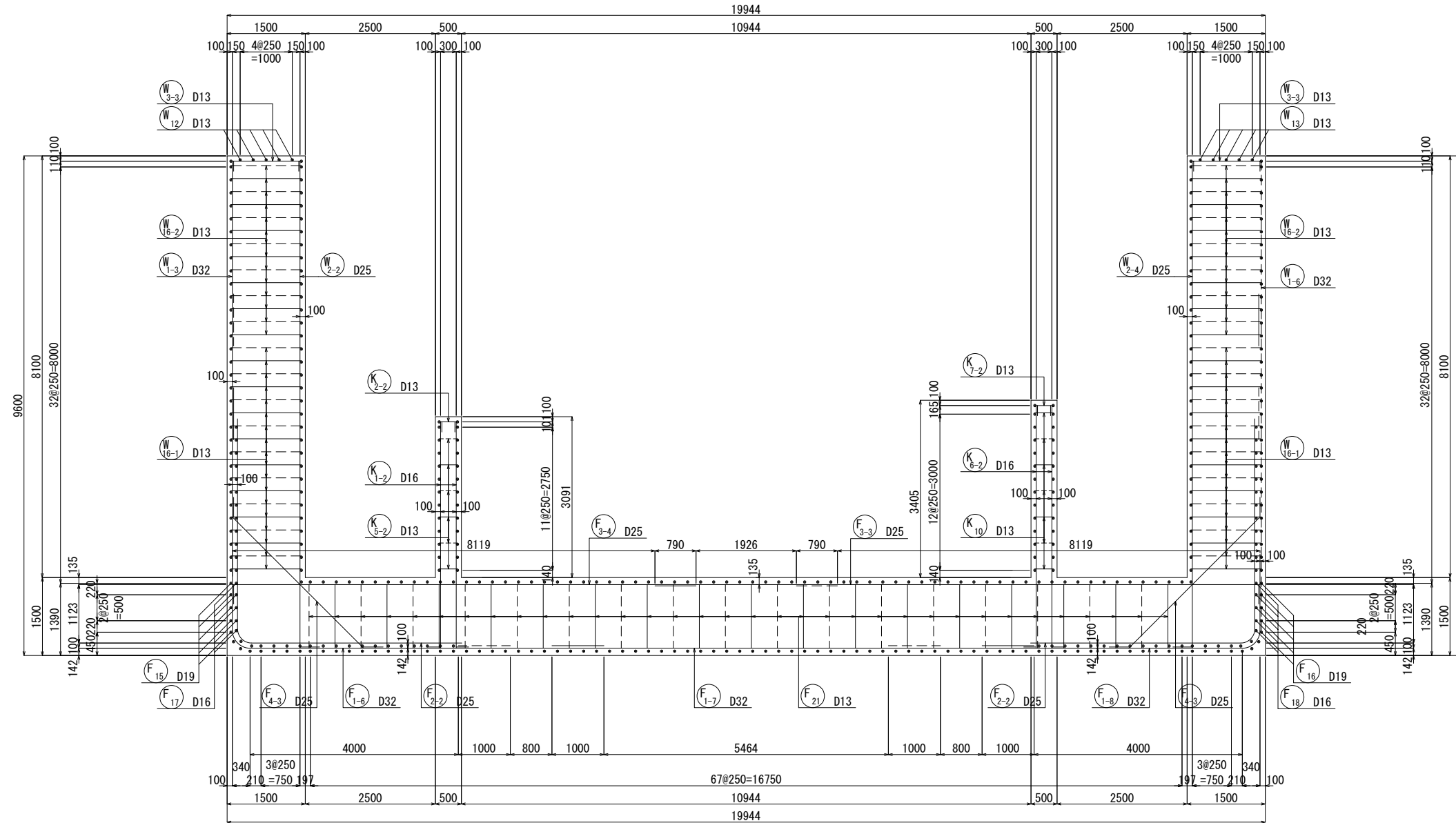

主鉄筋組立図 (ctc125)

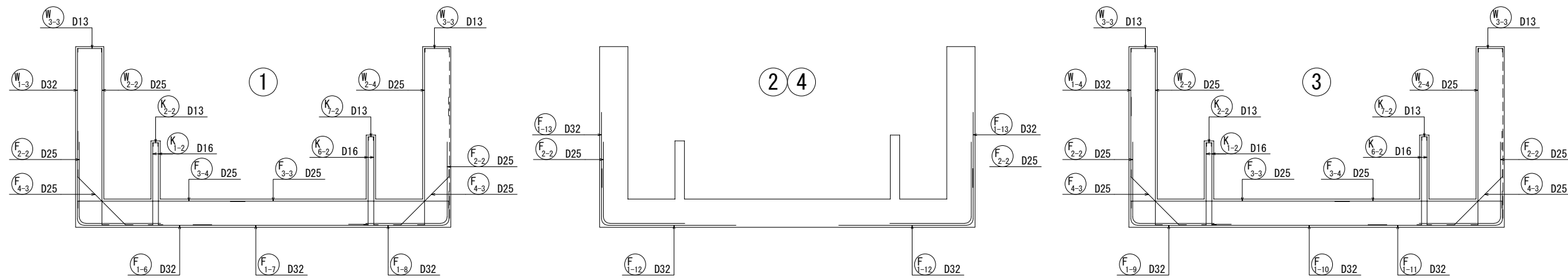

配置図 (平面図)

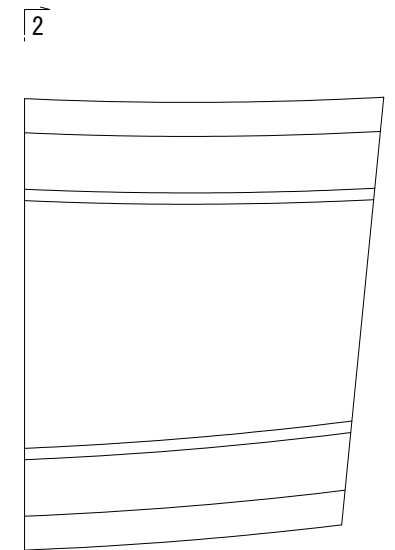

2

U型擁壁配筋図 S=1:50

(その3)

底板(上面)

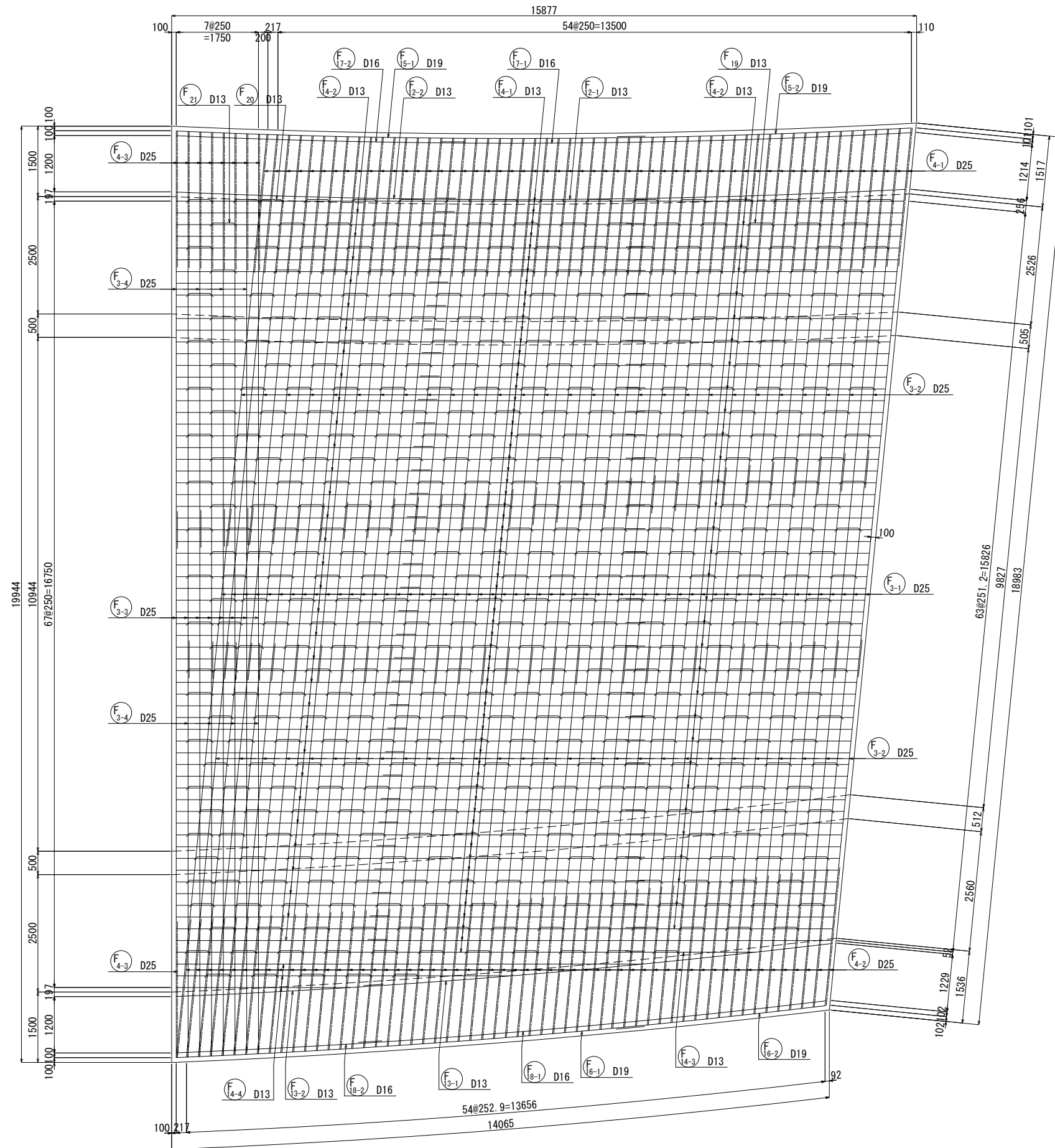

かぶり詳細図 S=1:30

底板(左端部)

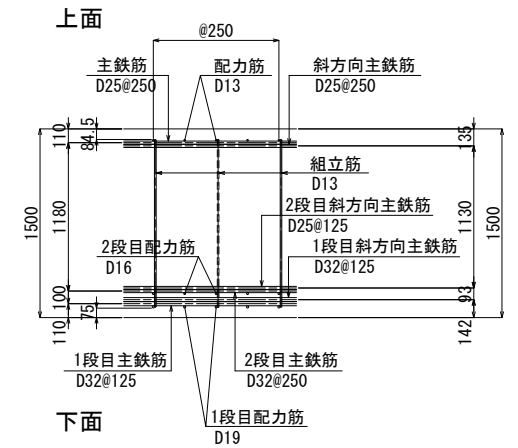

底板(中央部)

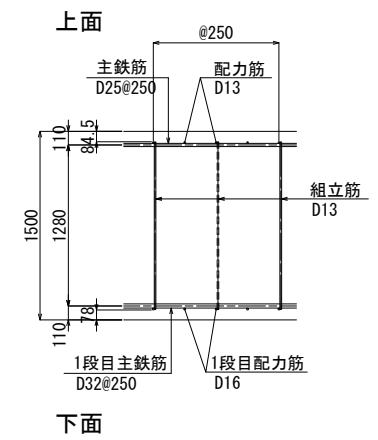

U型擁壁配筋図 S=1:50

(その4)

底板(下面)
(1段目鉄筋)

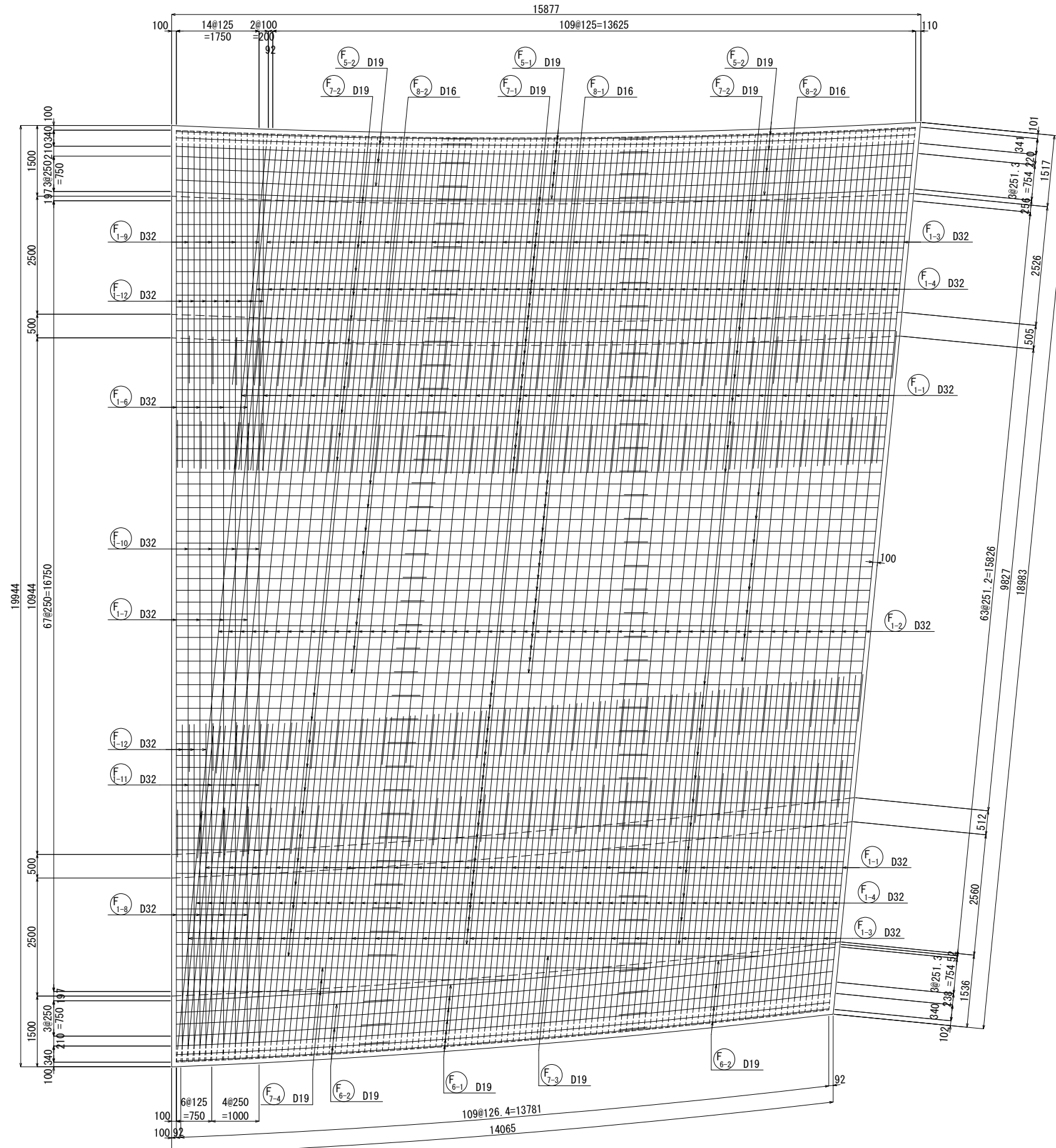

U型擁壁配筋図 S=1:50

(その6)

左側壁外面 (1段目鉄筋)

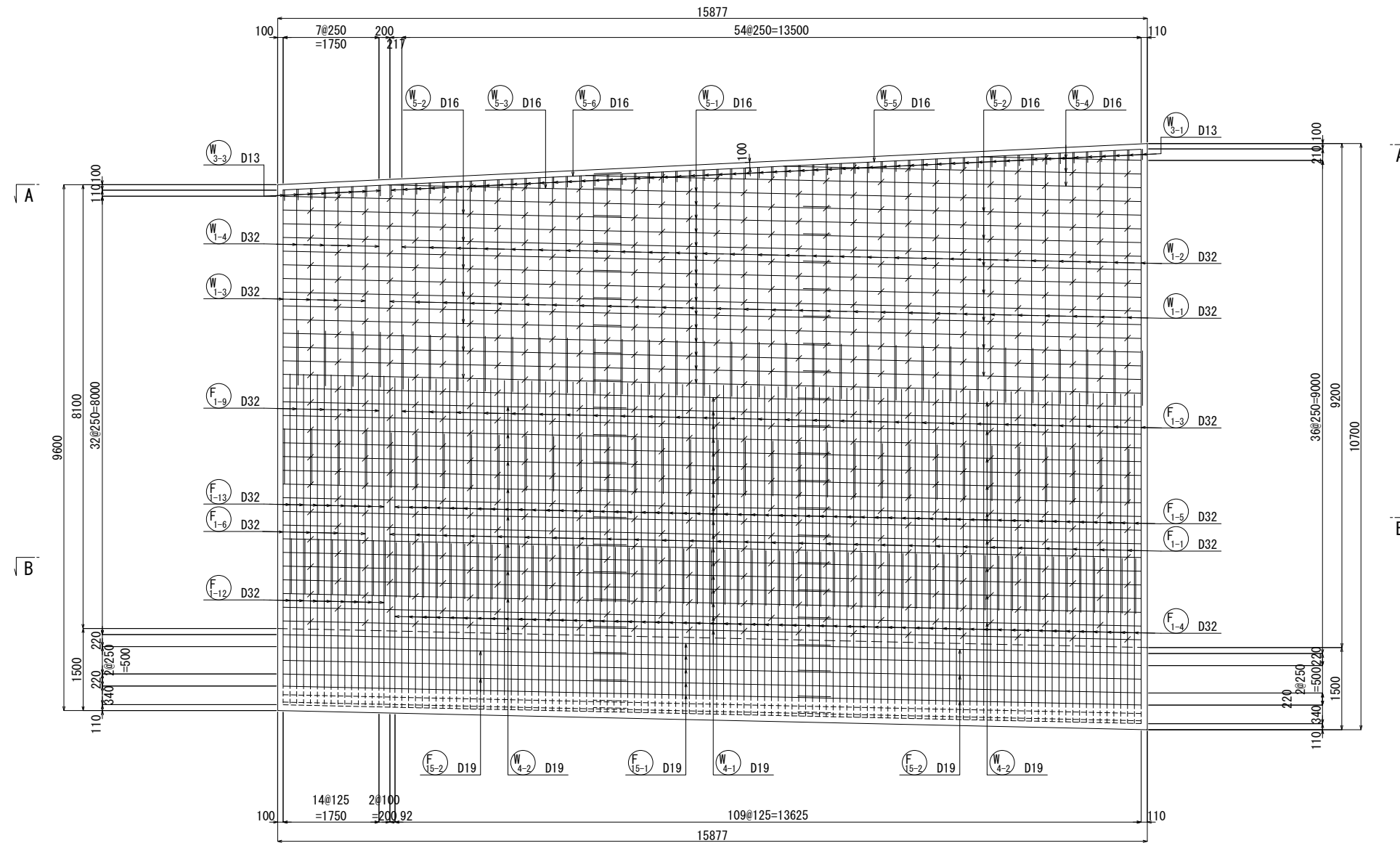

左側壁天端部

A - A

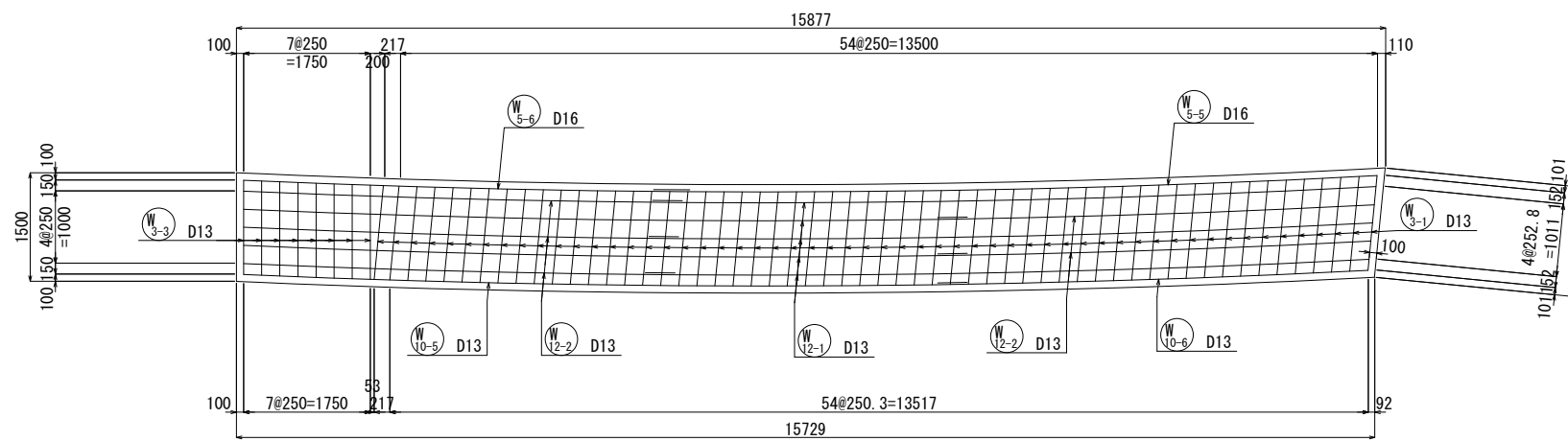

かぶり詳細図 S=1:30

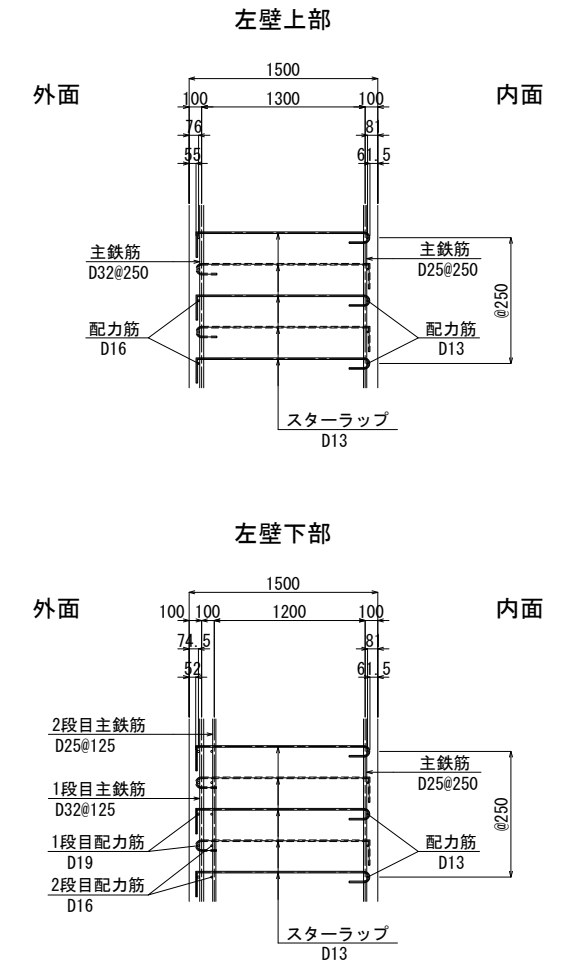

U型擁壁配筋図 S=1:50
(その7)

左側壁外面
(2段目鉄筋)

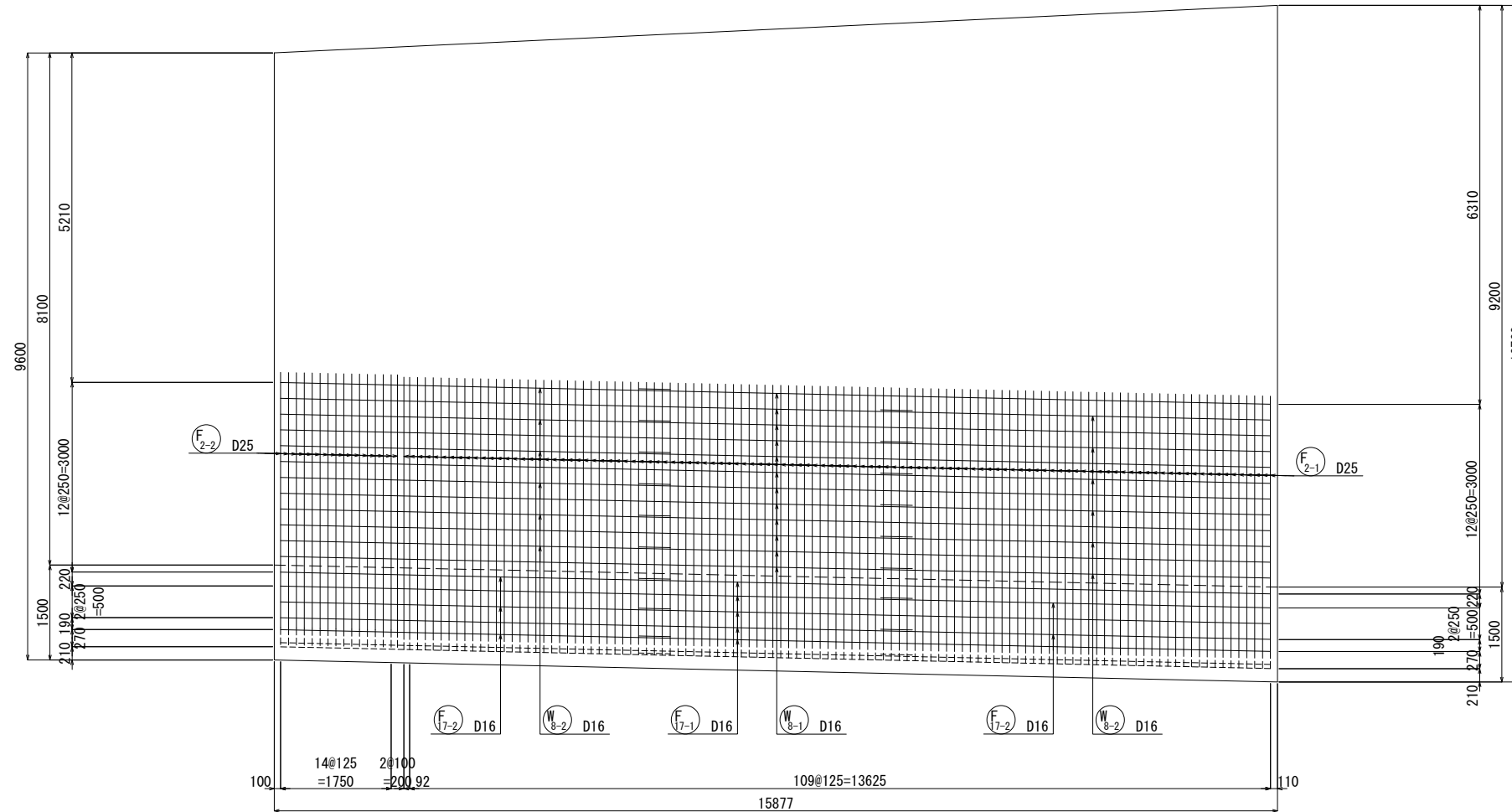

左側壁平断面図
B - B

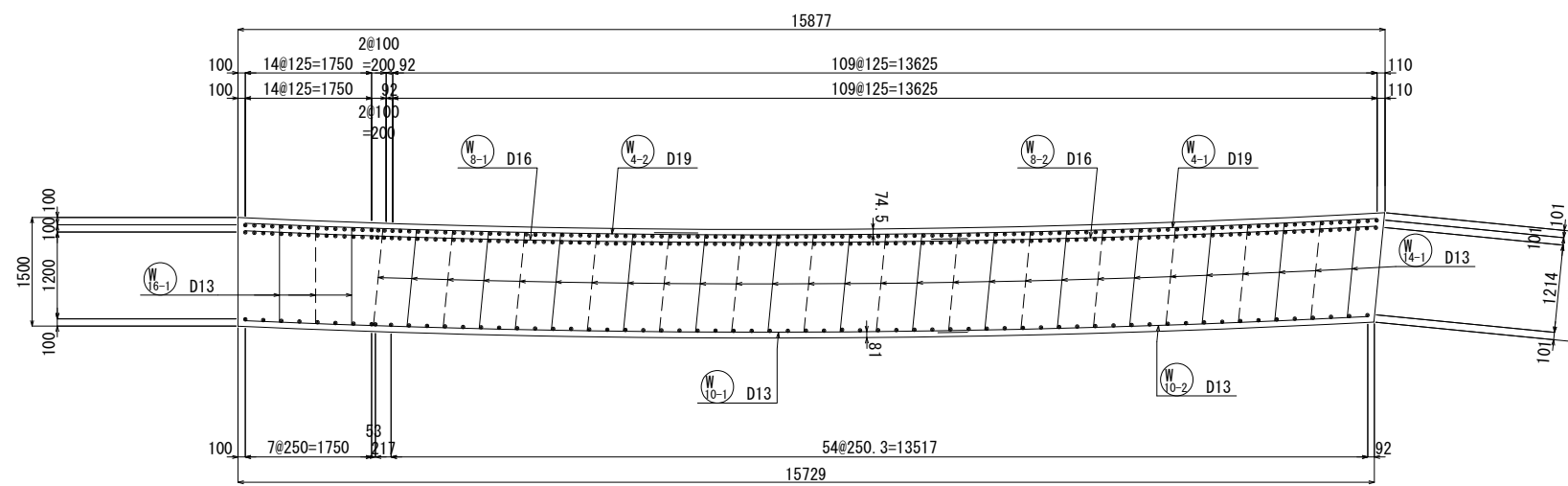

U型擁壁配筋図 S=1:50
(その8)

左側壁内面

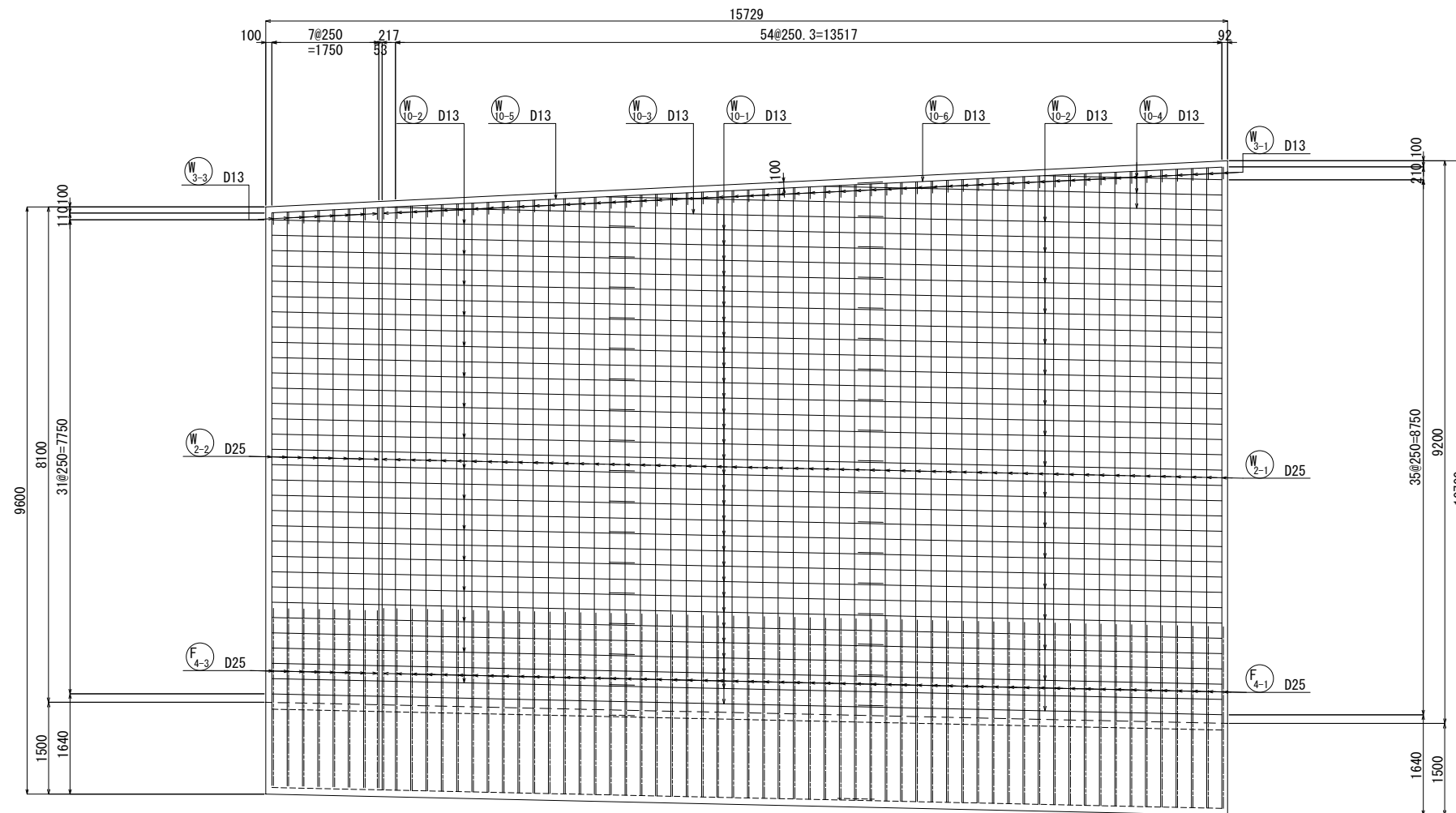

U型擁壁配筋図 S=1:50

(その9)

右側壁外面 (1段目鉄筋)

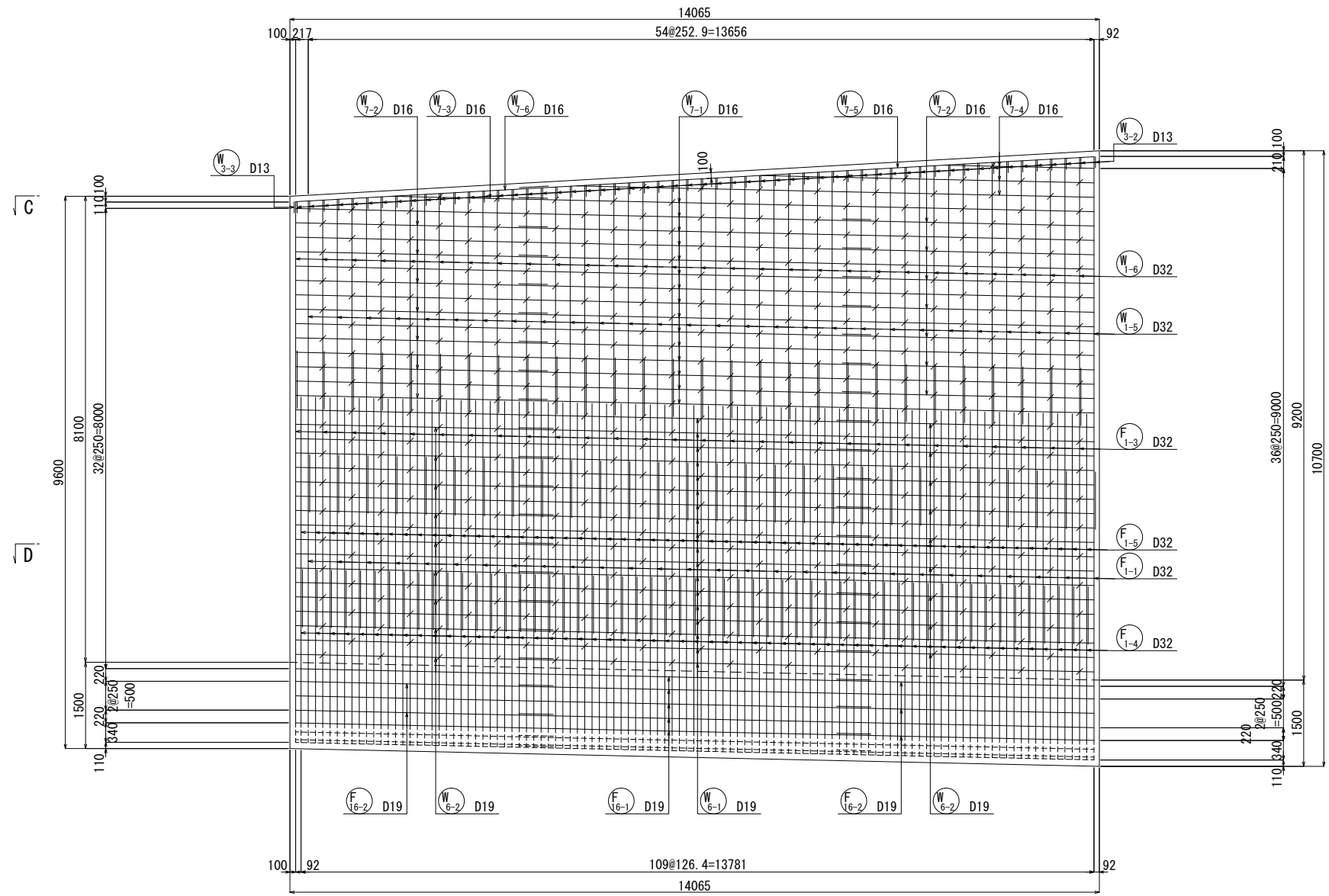

右側壁天端部

C - C

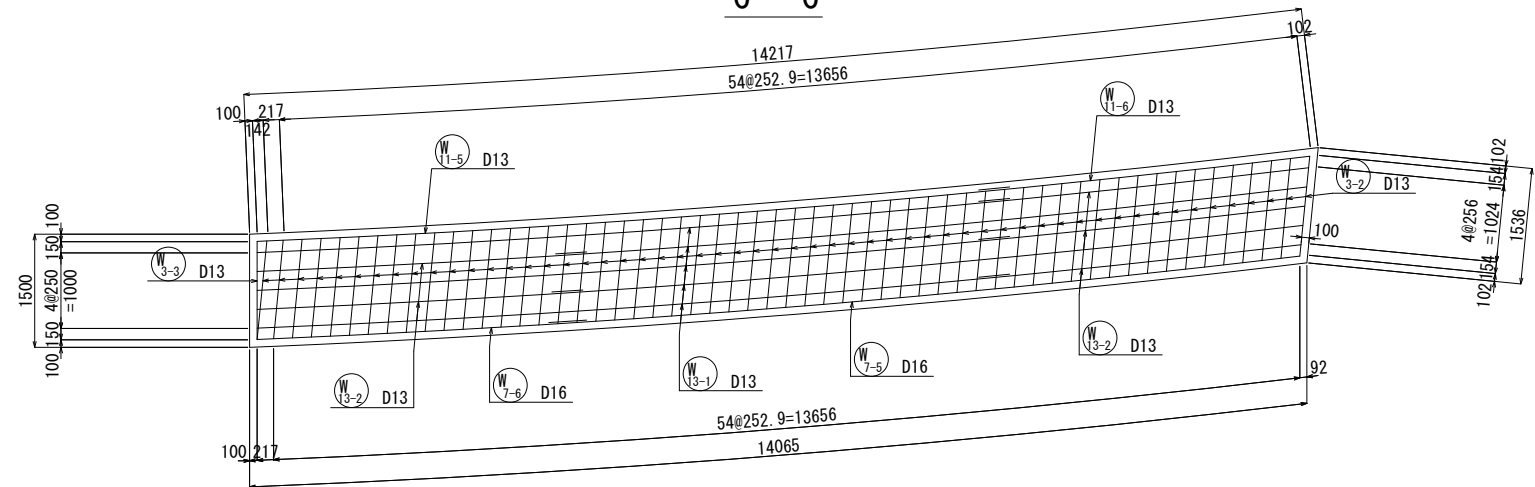

かぶり詳細図 S=1:30

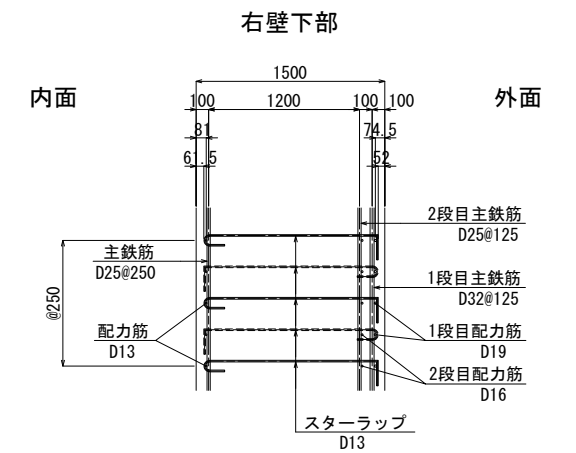
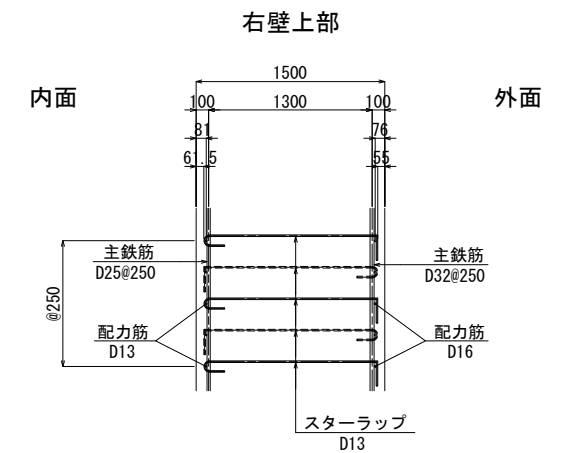

U型擁壁配筋図 S=1:50
(その10)

右側壁外面
(2段目鉄筋)

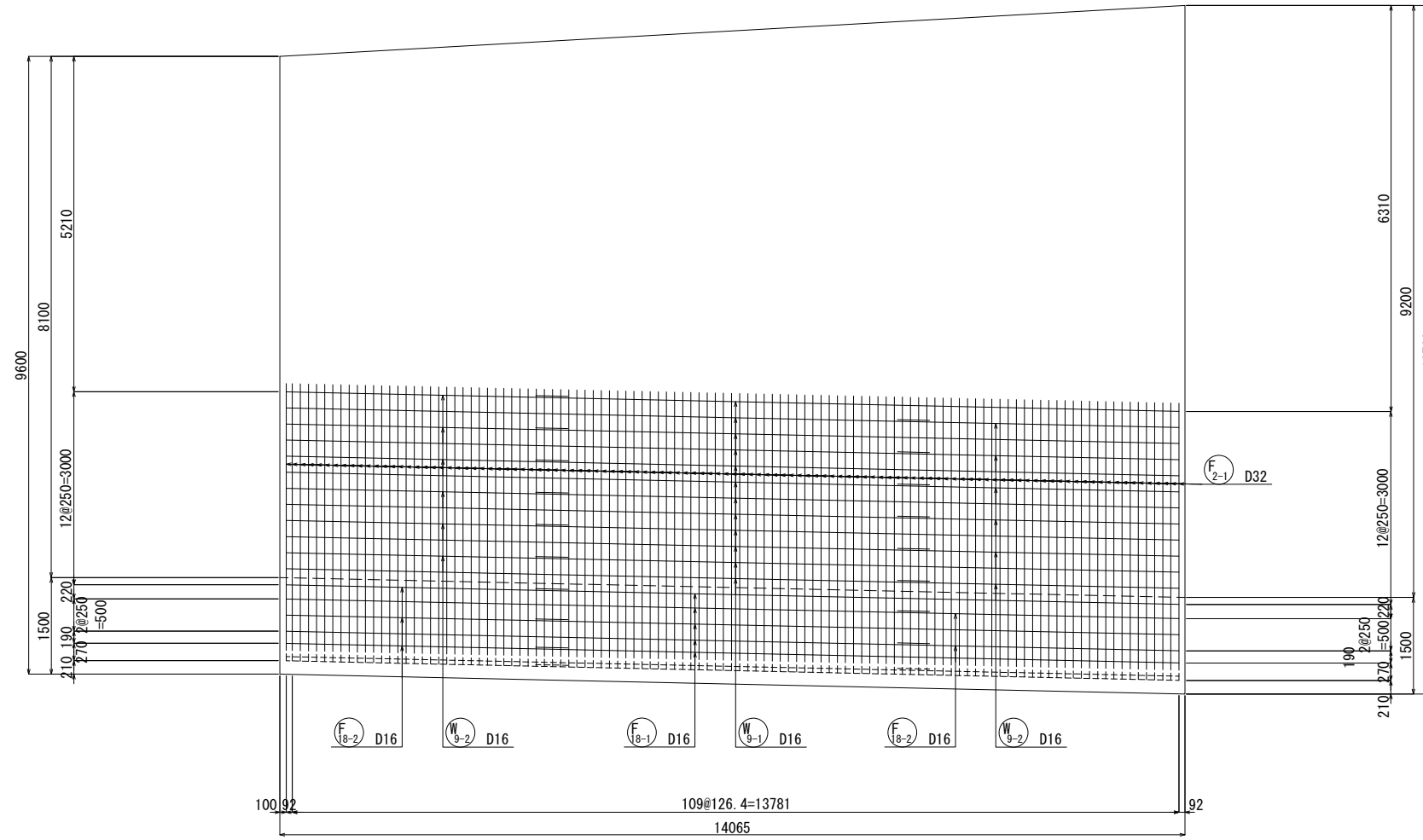

右側壁平断面図
D - D

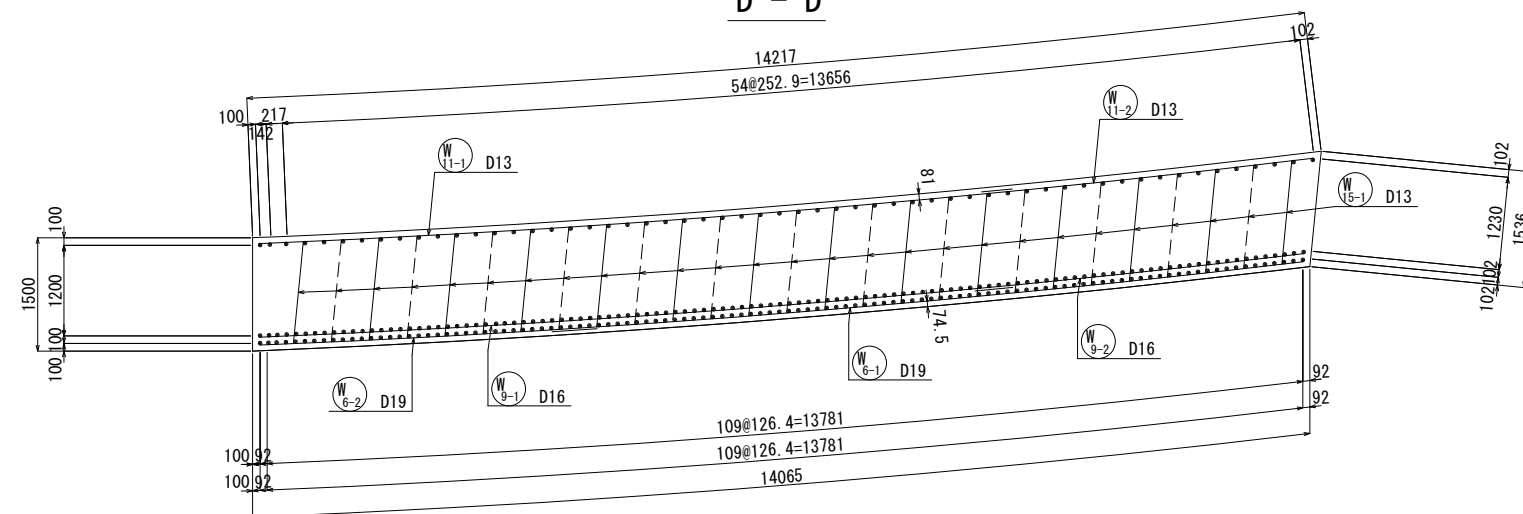

U型擁壁配筋図 S=1:50

(その11)

右側壁内面

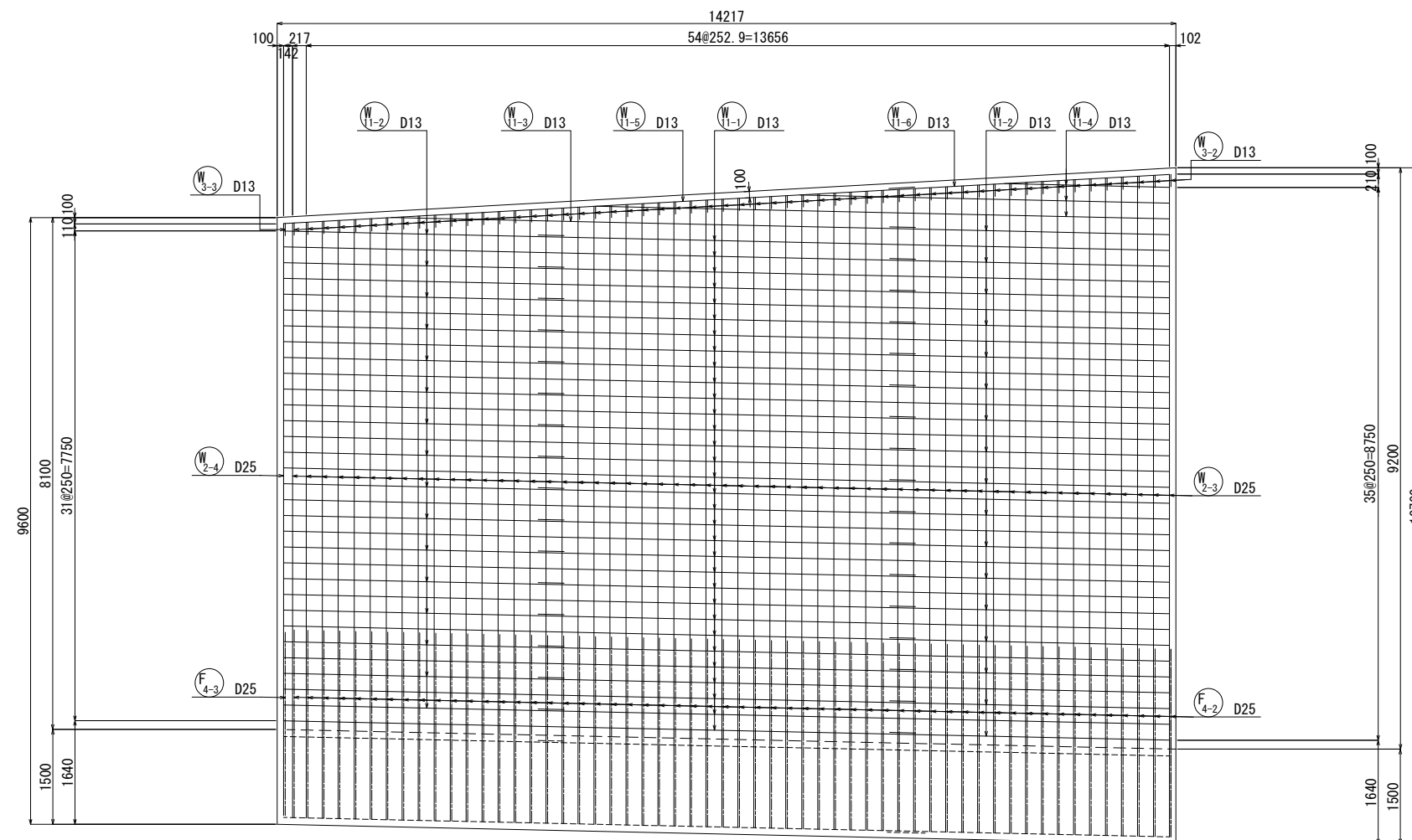

U型擁壁配筋図 S=1:50 (その12)

左側水路壁内面 (歩道側) 3 - 3

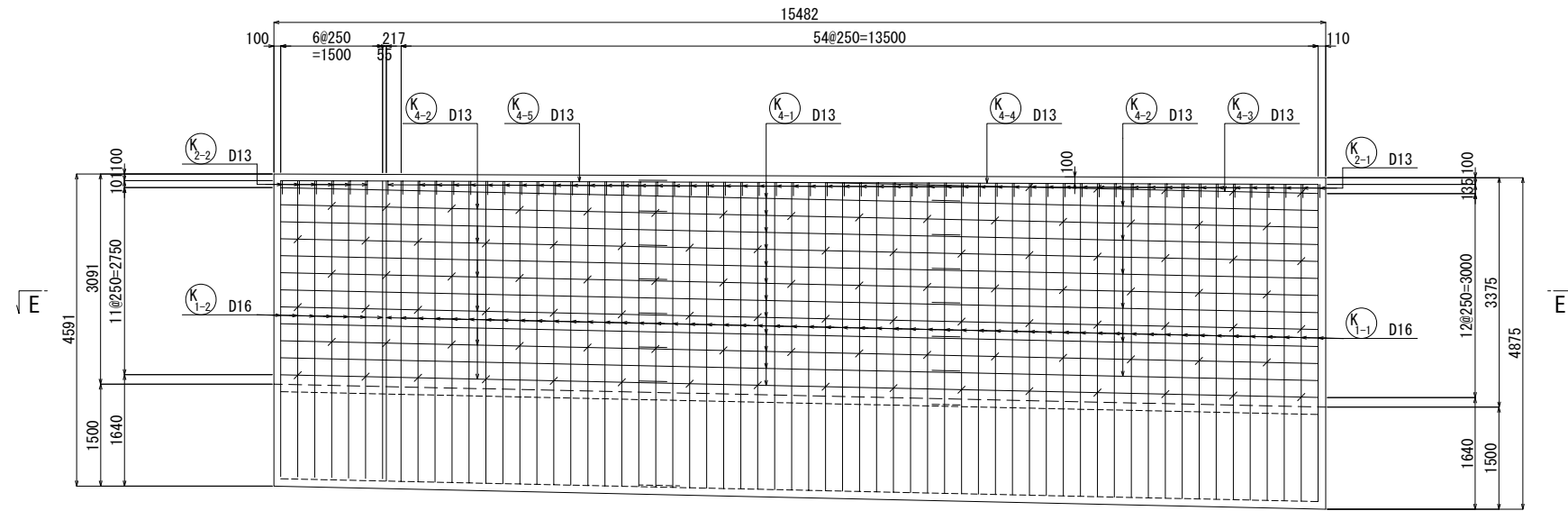

左側水路壁外面 (車道側) 4 - 4

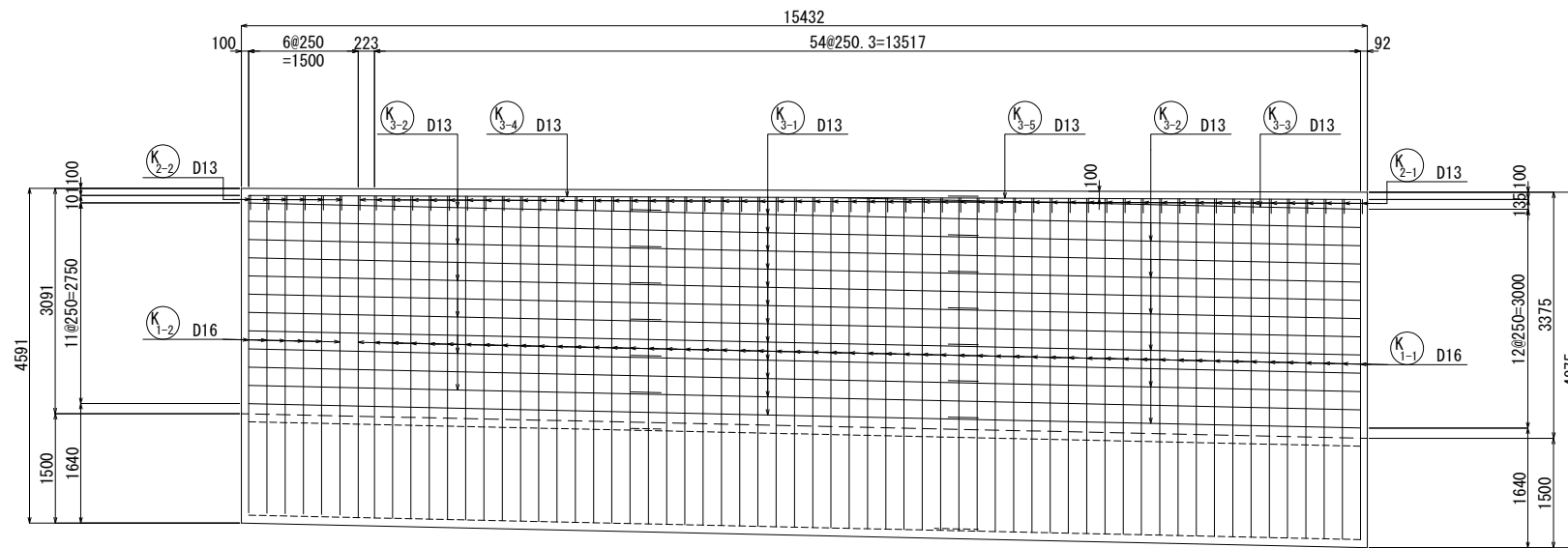

左側水路壁 E - E

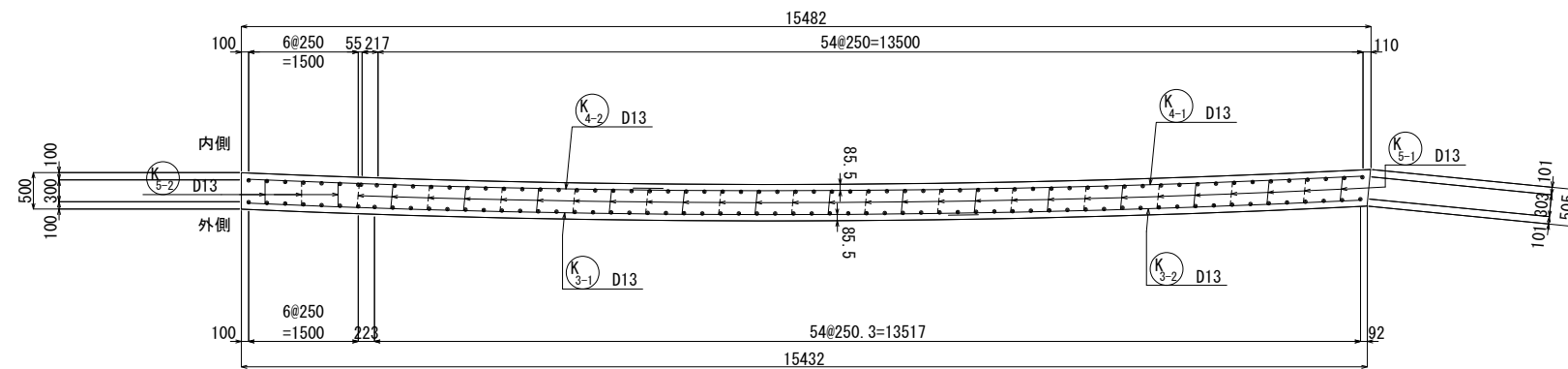

かぶり詳細図 S=1:30

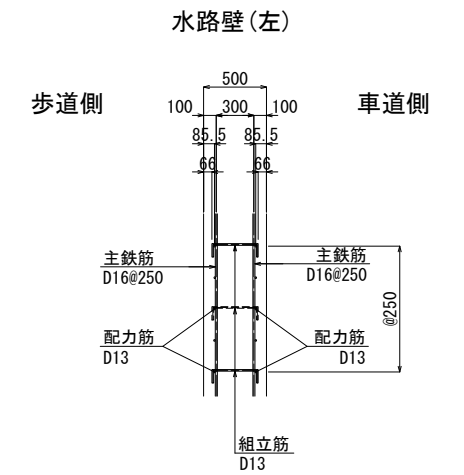

配置図 (平面図)

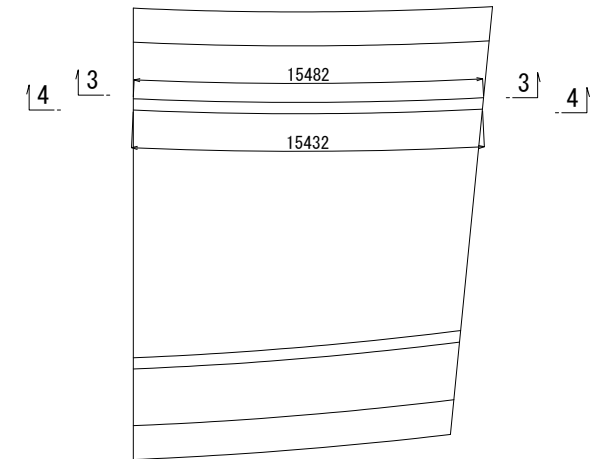

U型擁壁配筋図 S=1:50

(その13)

右側水路壁内面 (歩道側) 5 - 5

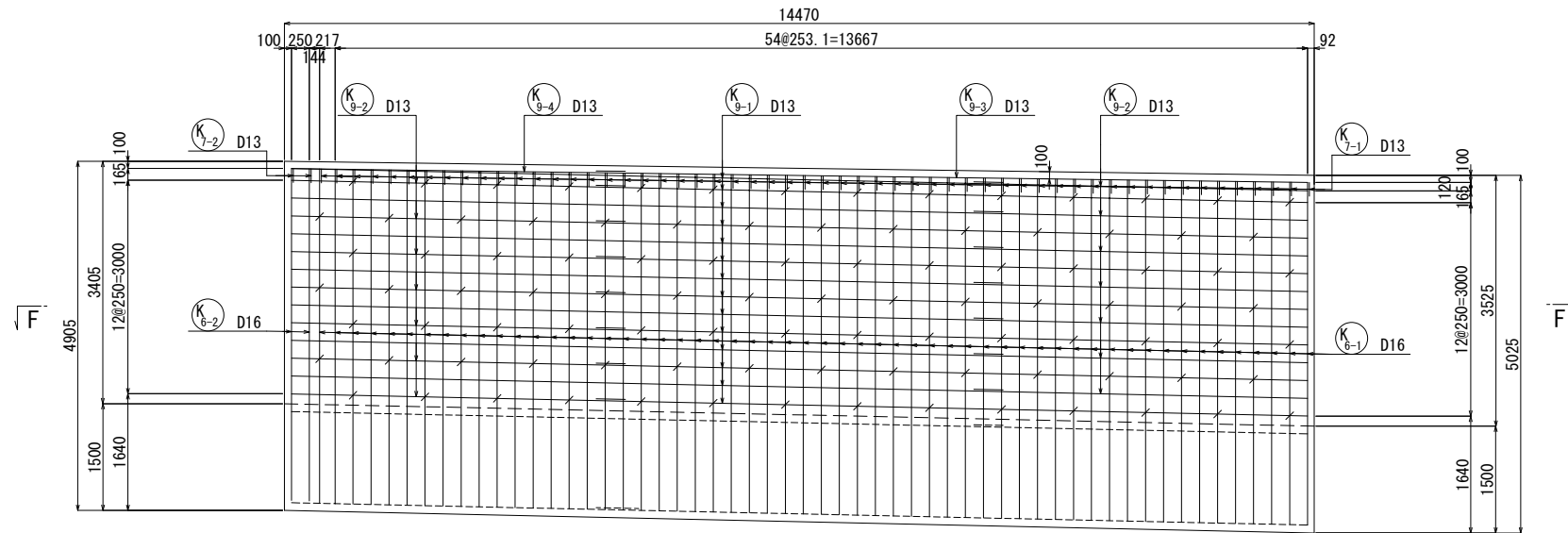

右側水路壁外面 (車道側) 6 - 6

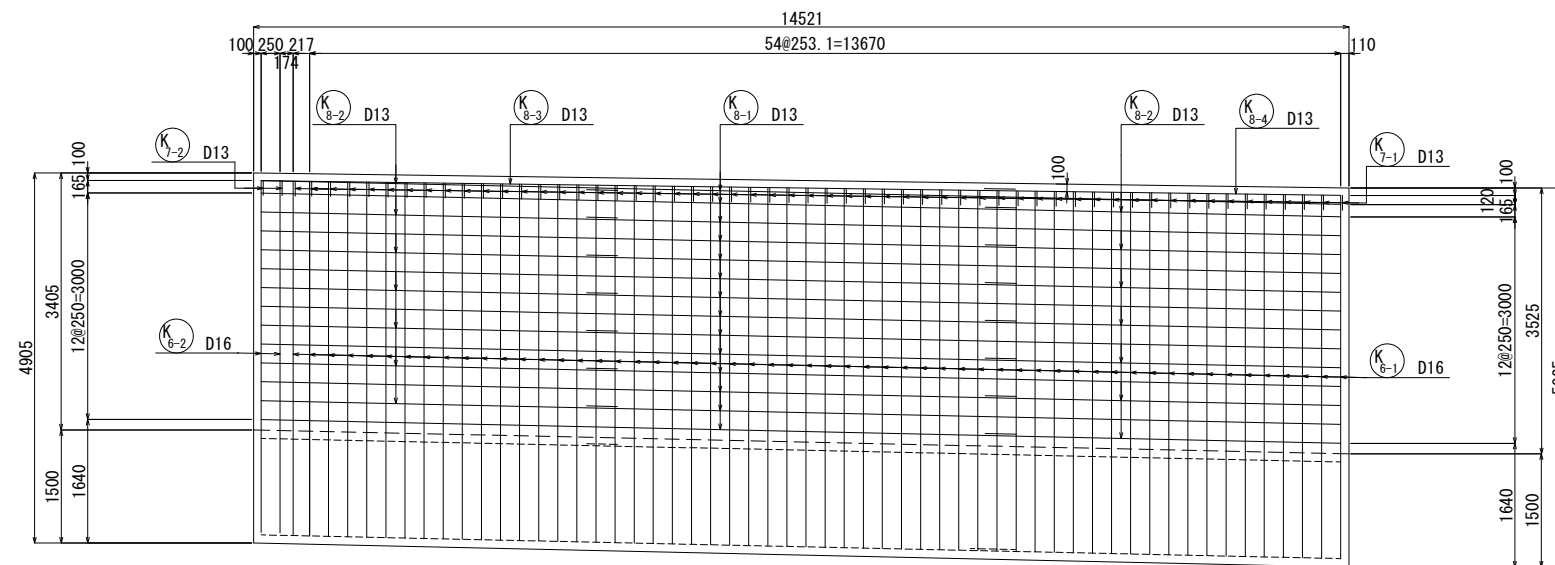

右側水路壁 F - F

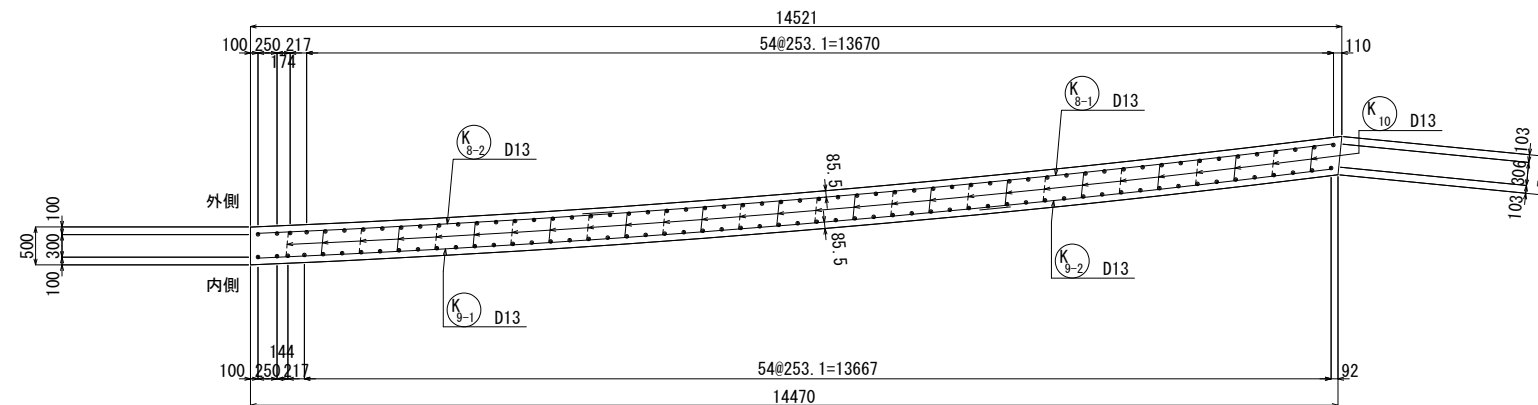

かぶり詳細図 S=1:30

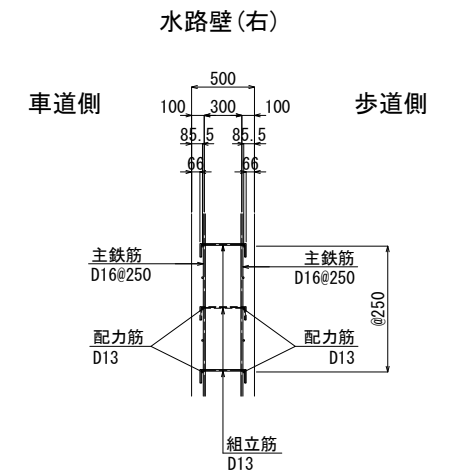

配置図 (平面図)

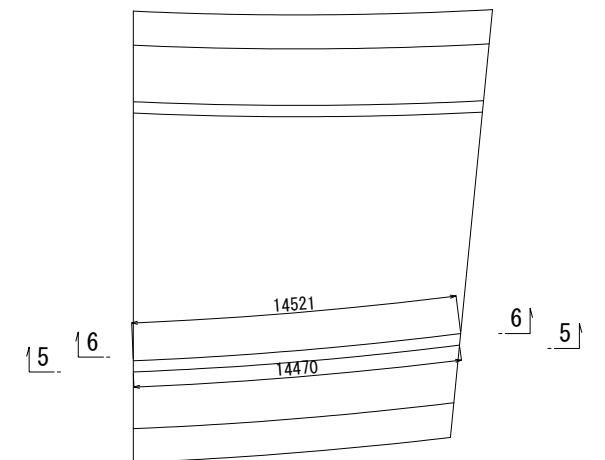

U型擁壁配筋図 S=1:50 (その14)

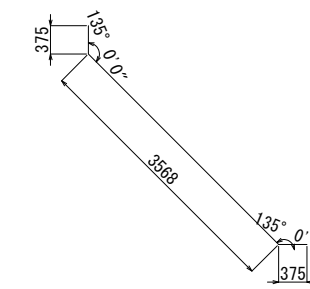
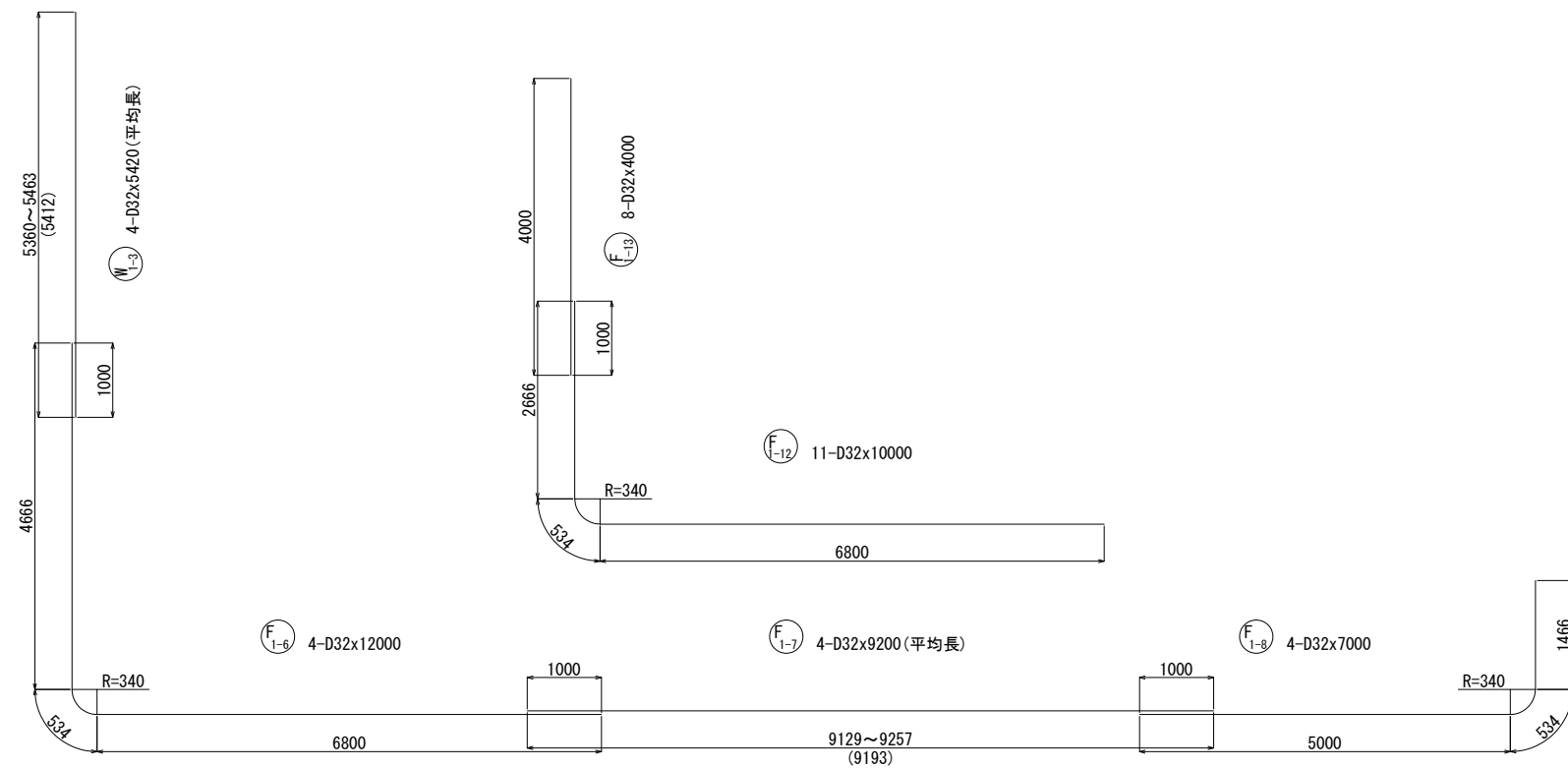
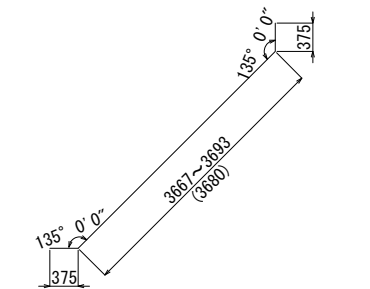
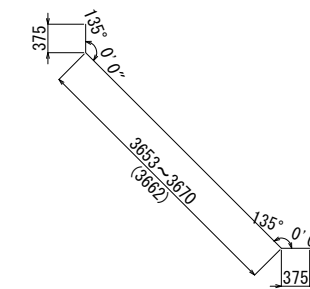
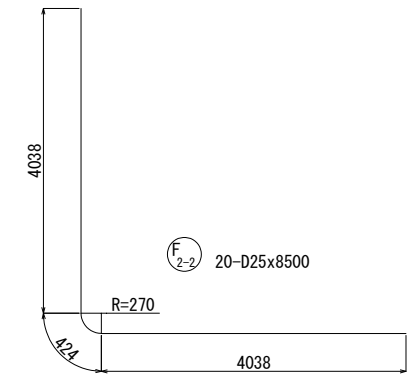
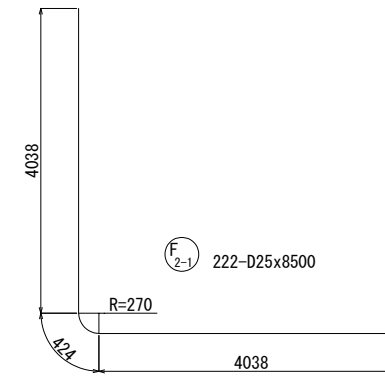
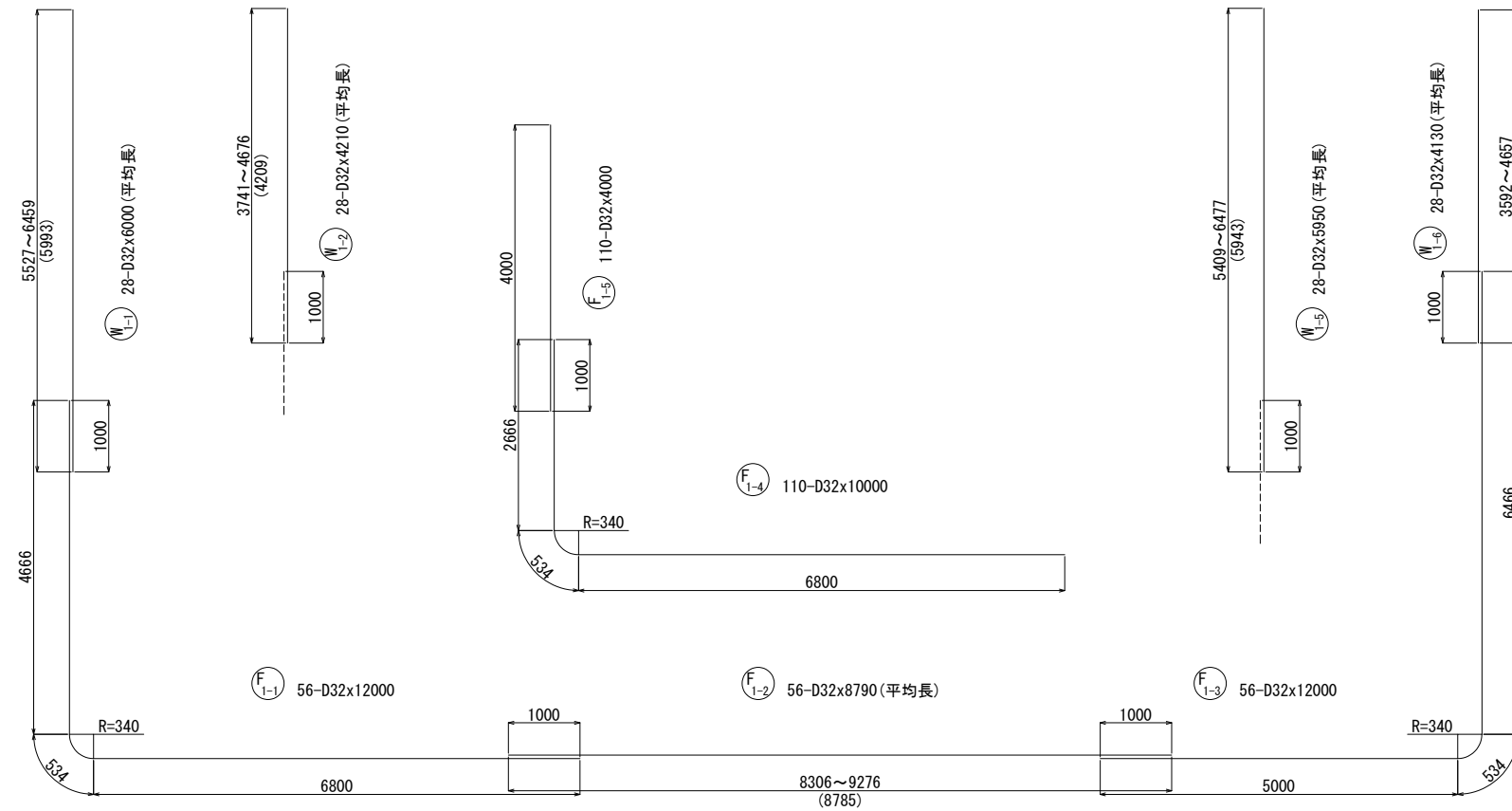

U型擁壁配筋図 S=1:50 (その15)

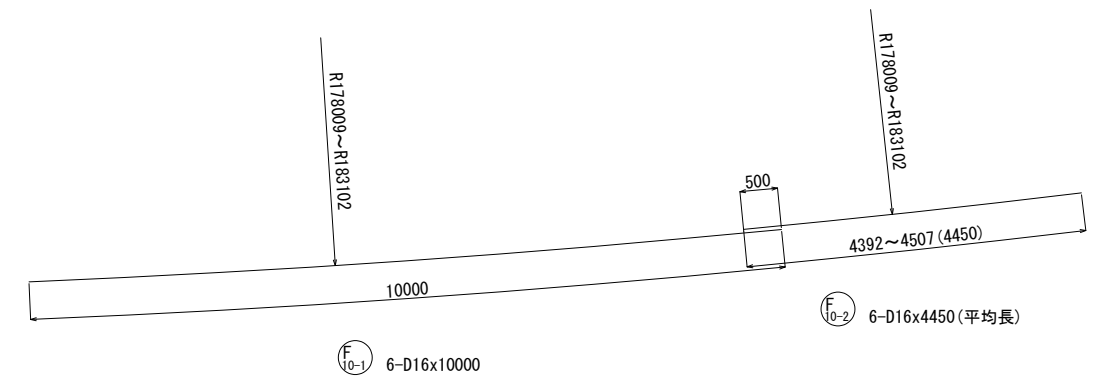
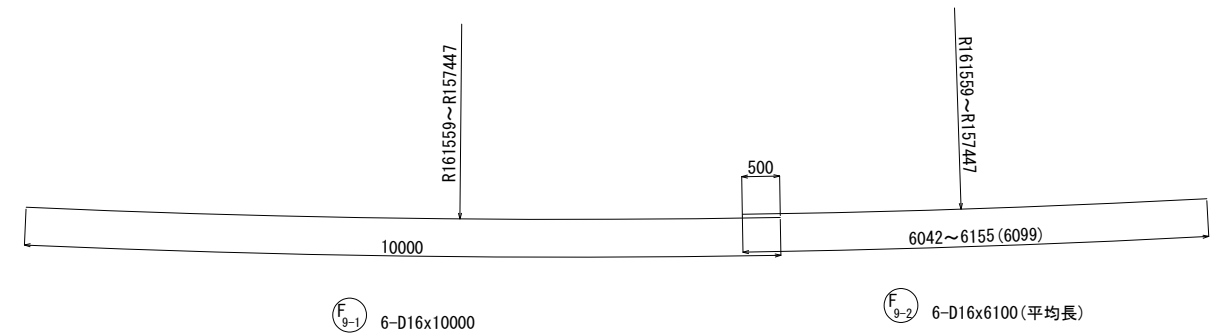
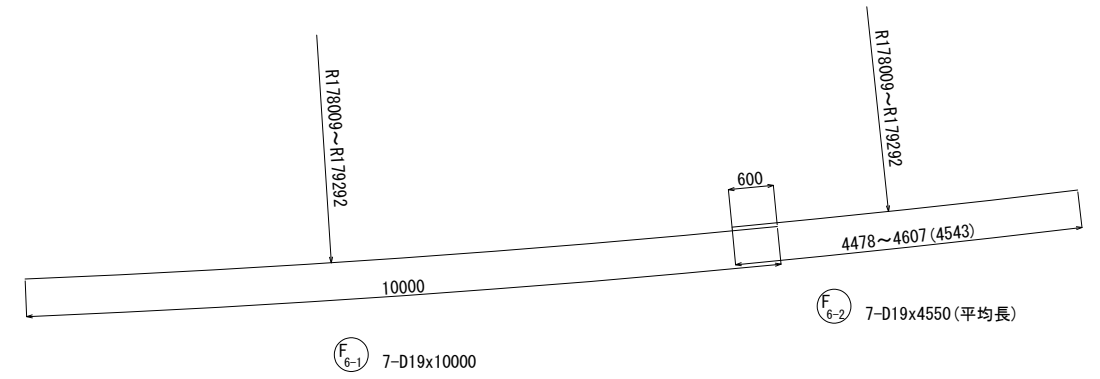
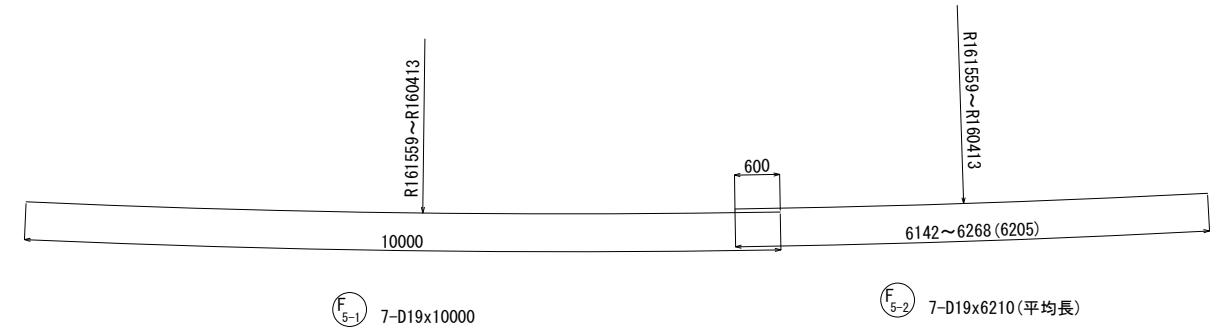
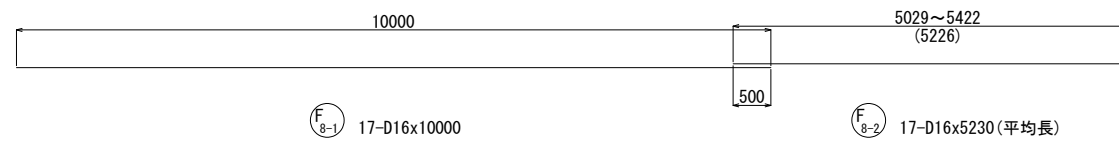
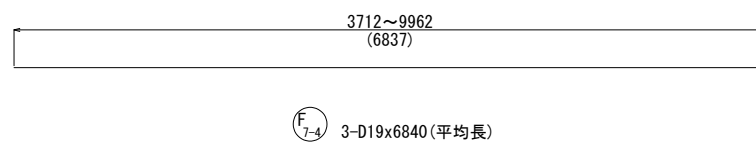
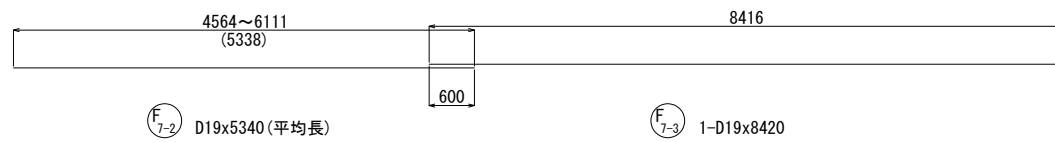
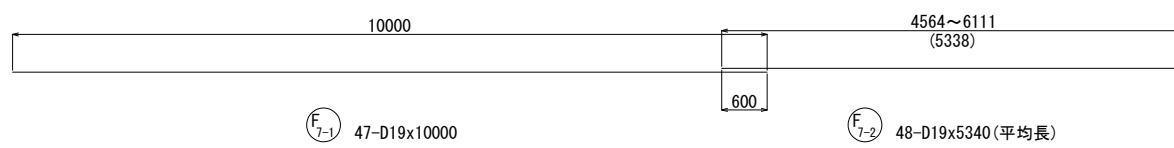
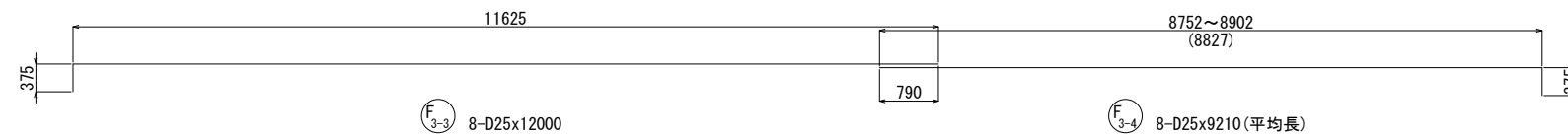
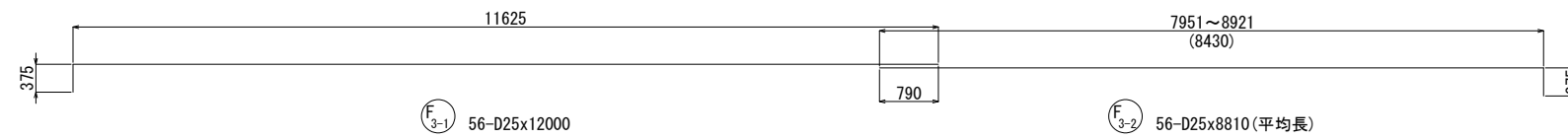
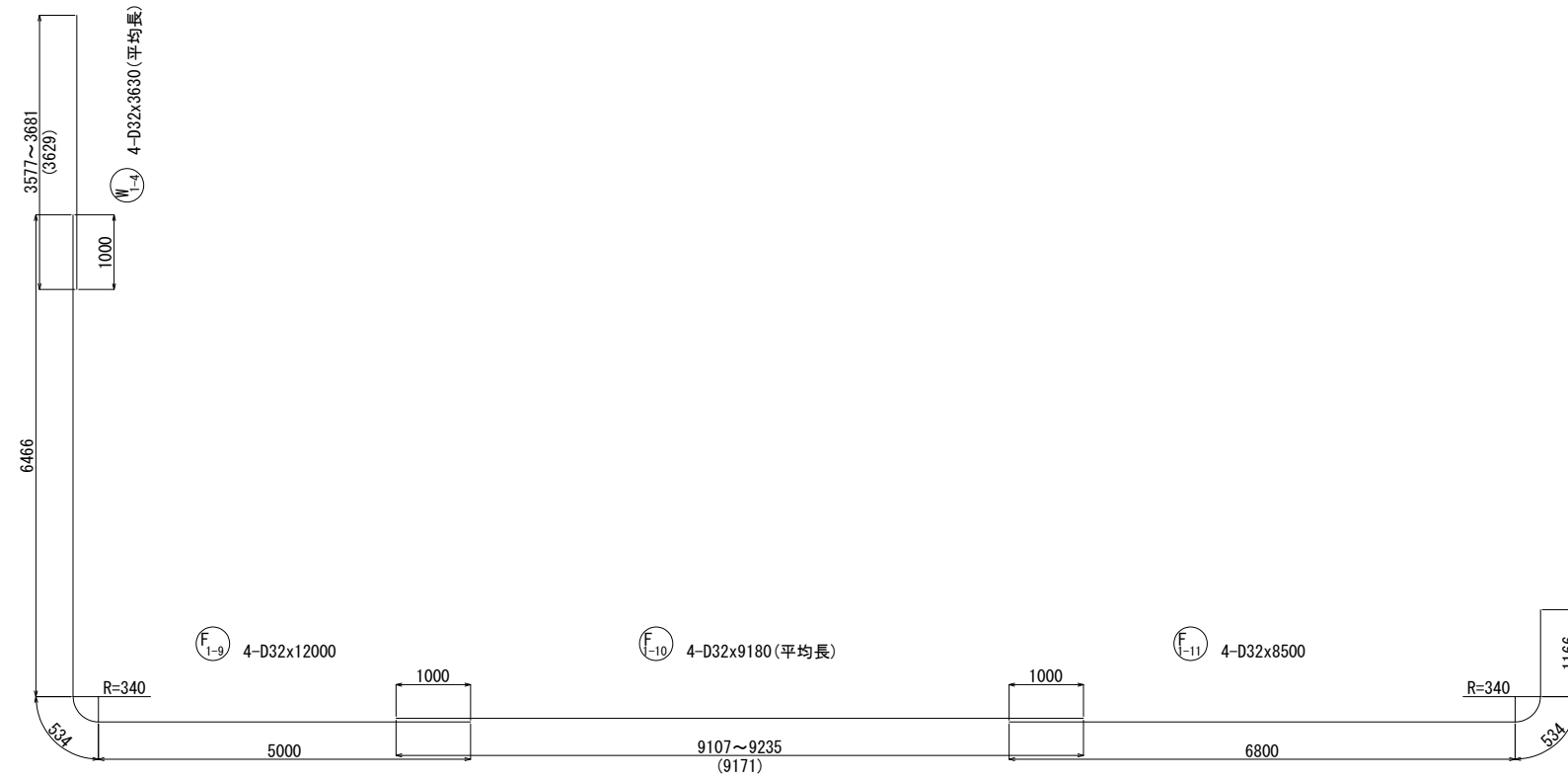

U型擁壁配筋図 S=1:50 (その16)

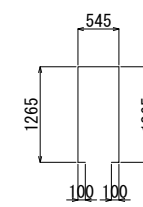
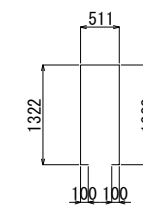
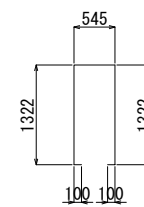
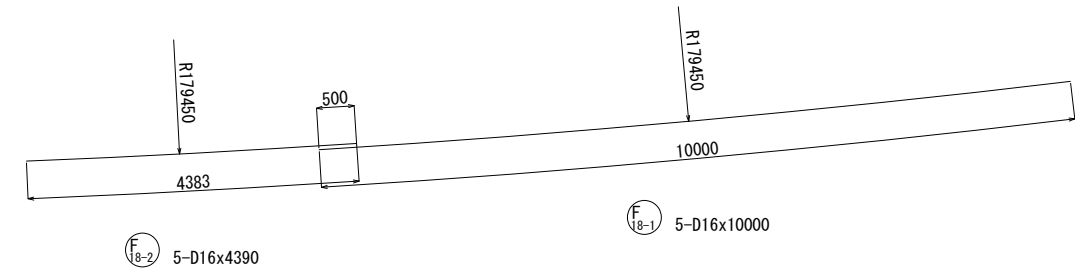
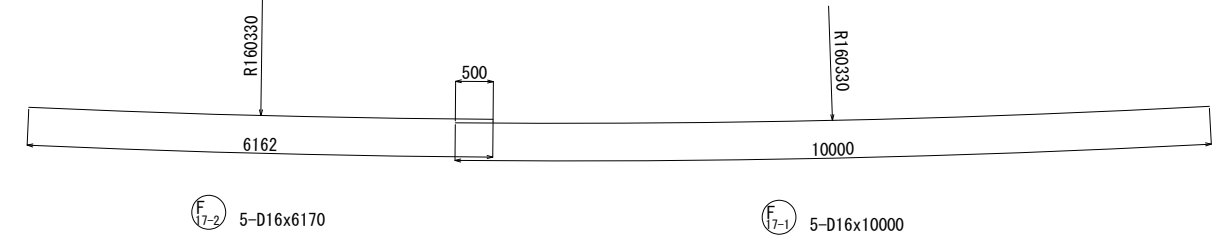
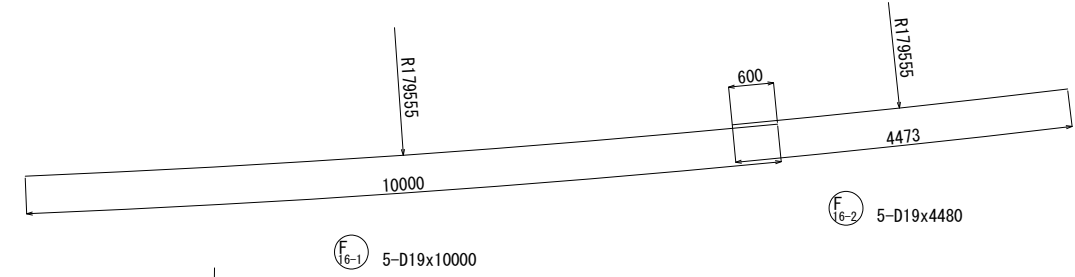
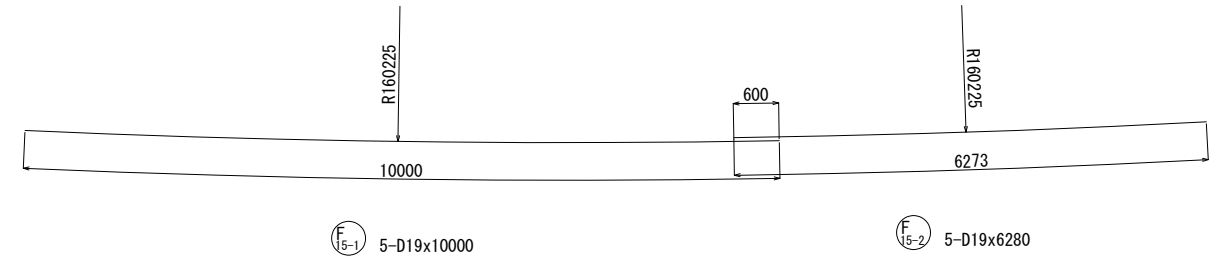
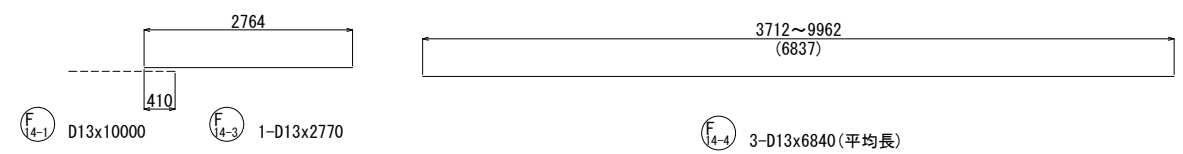
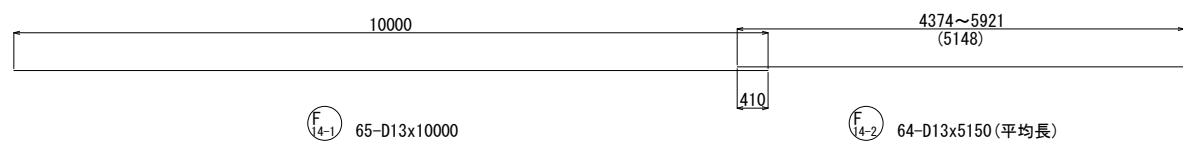
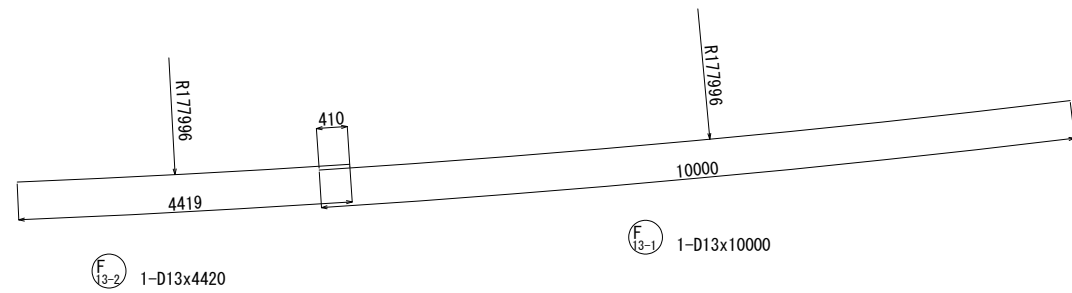
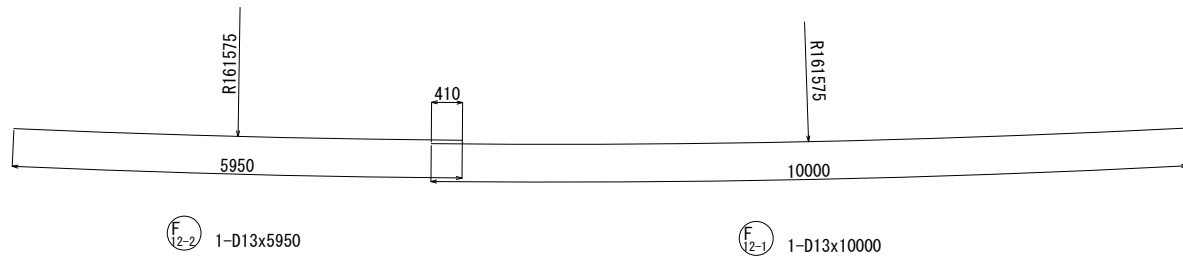
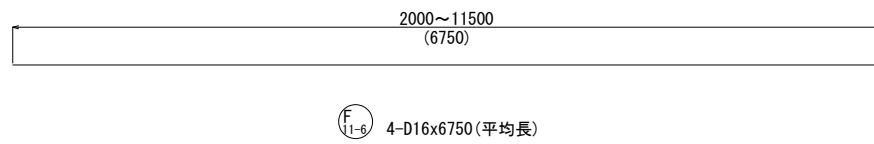
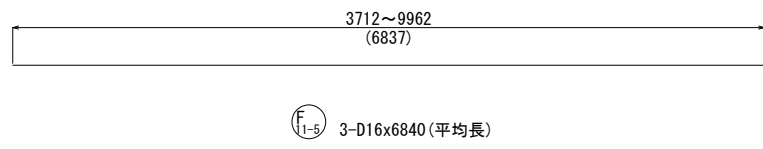
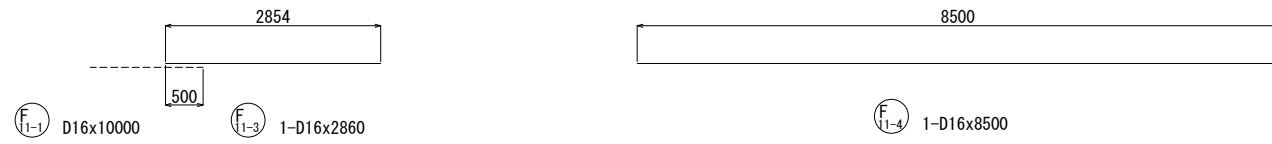
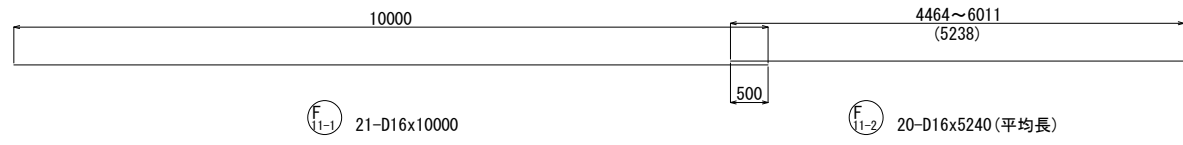

U型擁壁配筋図 S=1:50 (その17)

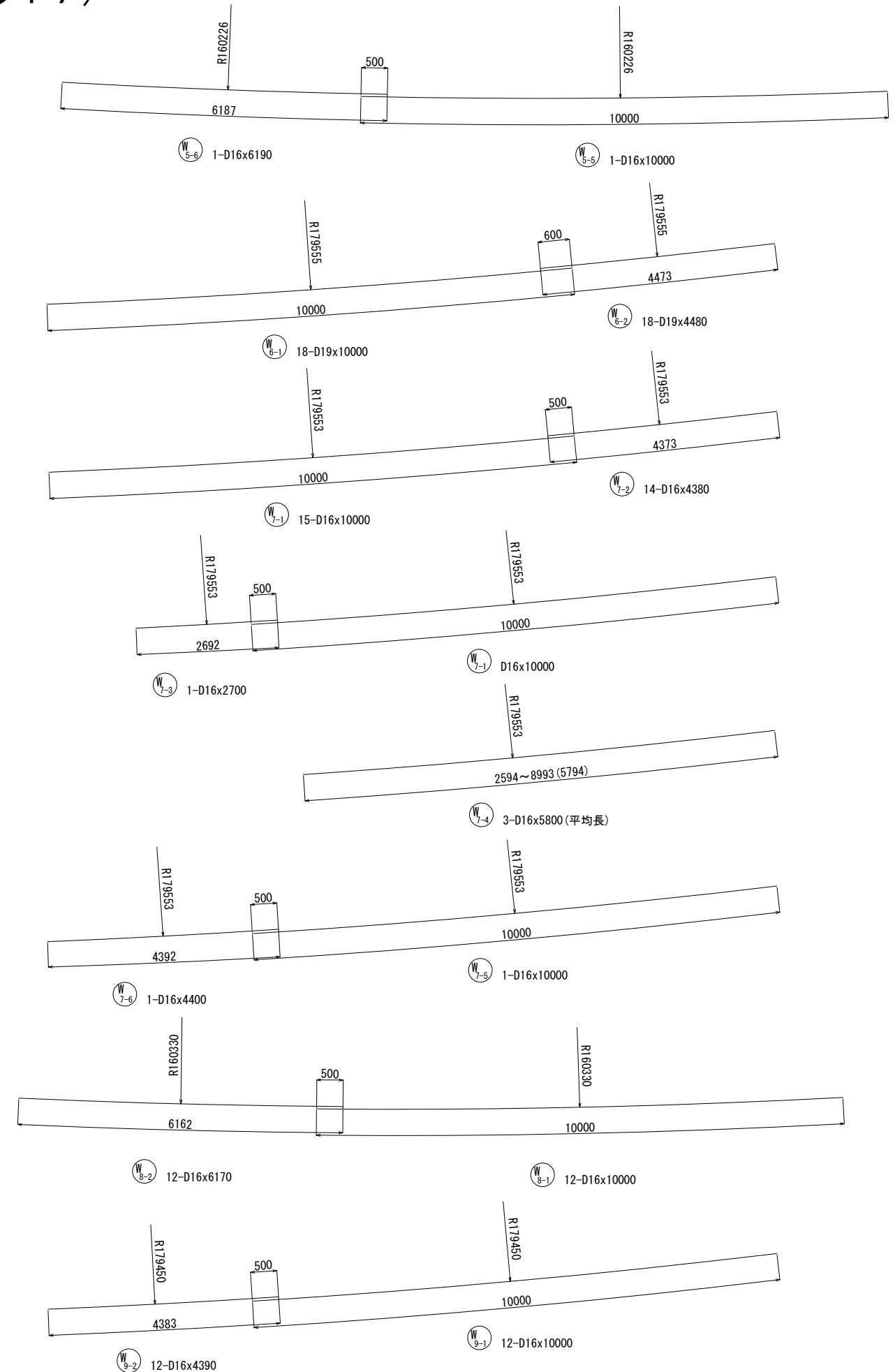
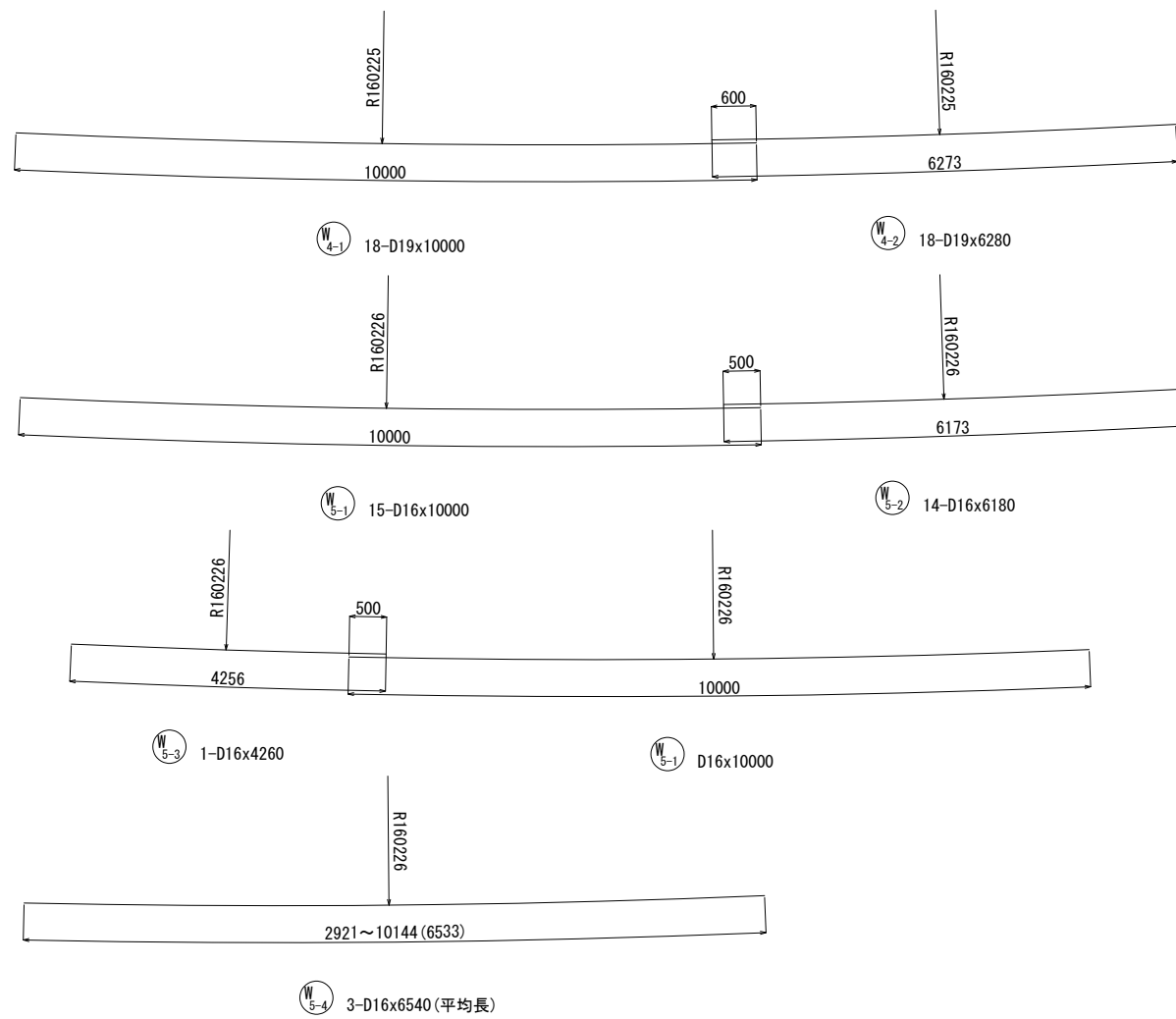
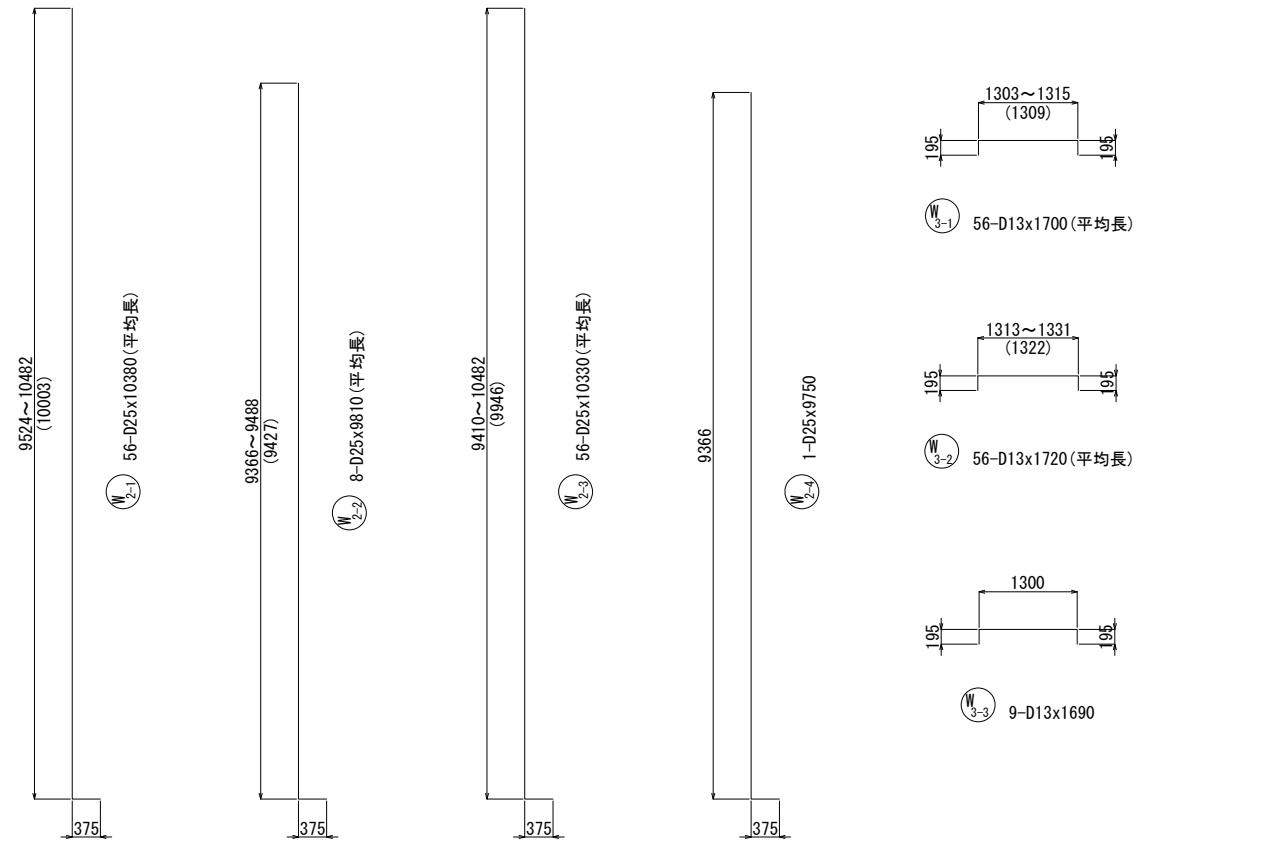

U型擁壁配筋図 S=1:50 (その18)

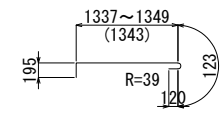
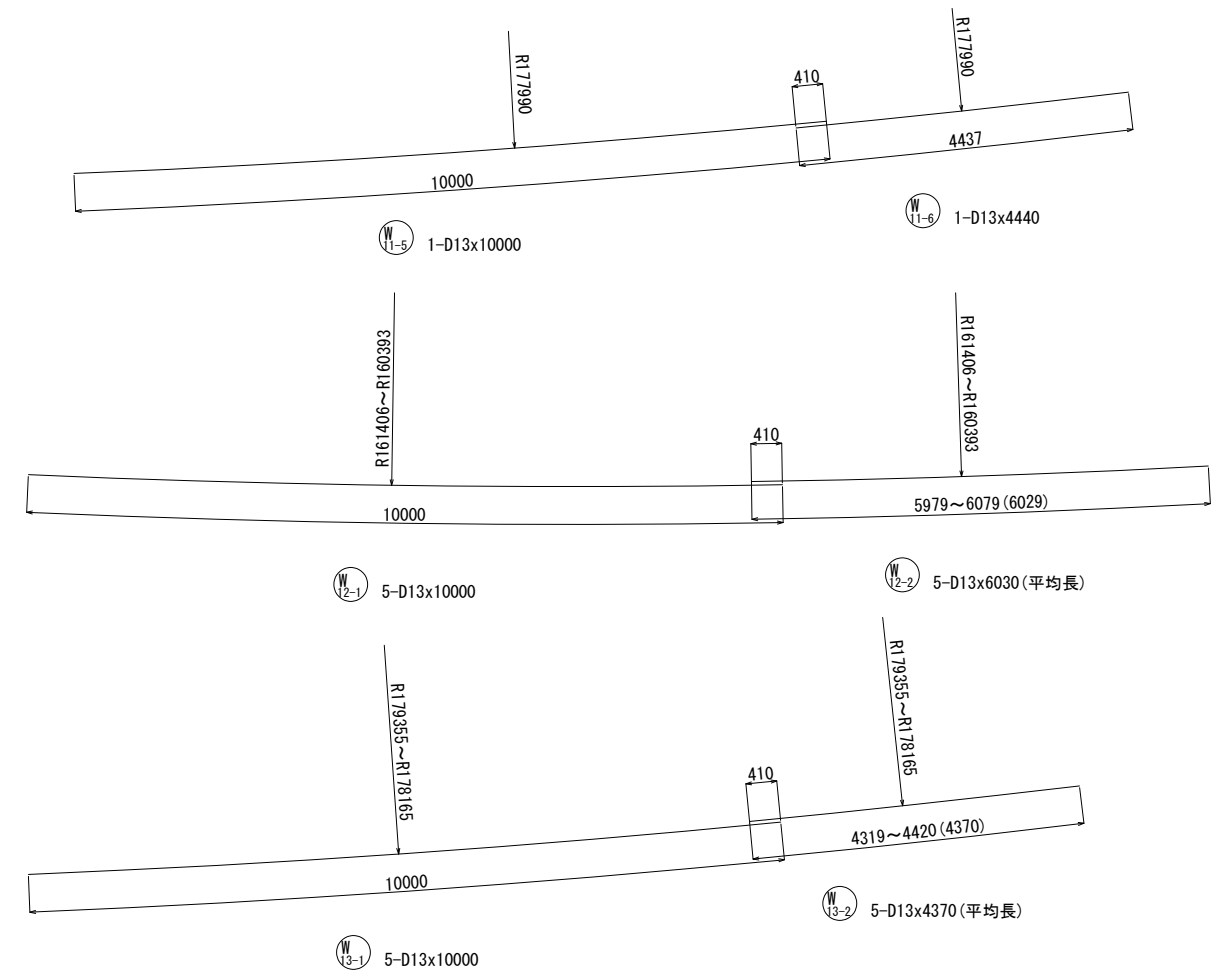
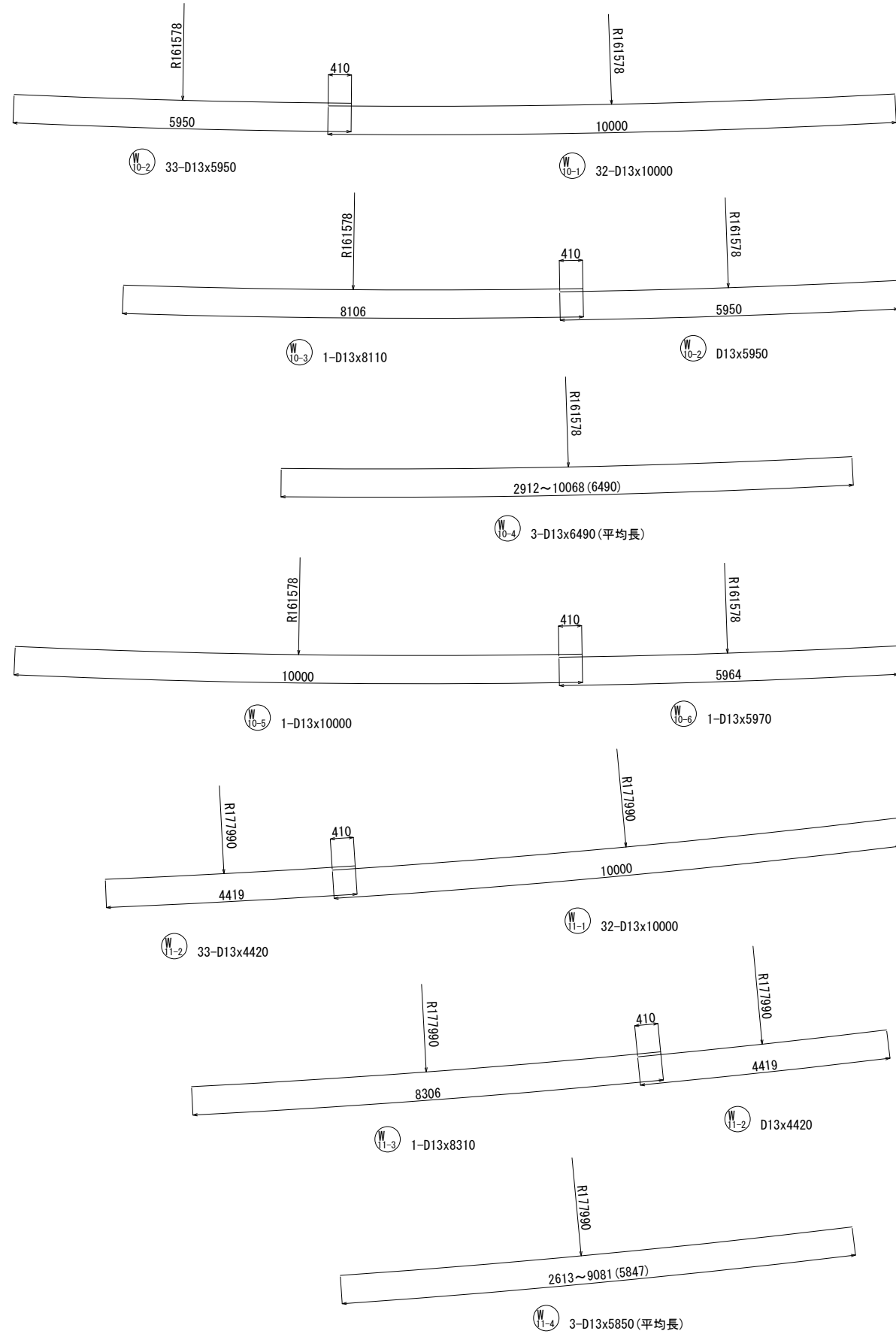

W14-1 252-D13x1790 (平均長)

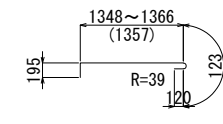

W15-1 243-D13x1800 (平均長)

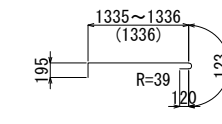

W16-1 27-D13x1780 (平均長)

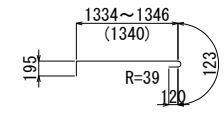

W14-2 226-D13x1780 (平均長)

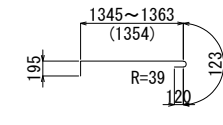

W15-2 216-D13x1800 (平均長)

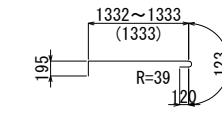

W16-2 21-D13x1780 (平均長)

U型擁壁配筋図 S=1:50

(その19)

